

RESEARCH, DESIGN AND MANUFACTURE OF THE HIGH-PRECISION MULTI-CHANNEL POWER SUPPLY AND MEASUREMENT DEVICE

Nguyen Van Dua

*National Center for Technological
Progress
Hanoi, Vietnam*

Do Van Thoi

*Thanhdong University
Hai Duong, Vietnam
thoidv@thanhdong.edu.vn*

ABSTRACT

In today's industry, data transmitters and sensors typically use analog signals of 4 to 20 milliamperes (mA) current or voltage signals of 0 to 10 volts direct current (VDC) to transmit data to a central control system utilizing a PLC or microcontroller circuit. It is essential to test and calibrate measurement and control systems in order to evaluate system performance, identify error reasons early, and re-calibrate the signal. In order to generate a standard signal source for system testing and calibration, high-precision, multi-function analog voltage and current measurement equipment is employed. In this study, we present the design and manufacture of a voltage and current analog signal generator with multiple applications. The device can generate a current signal in the range of 4 to 20 milliamperes with a maximum error of 0.05% and a DC voltage signal in the range of 0 to 10 volts with a maximum error of 0.05% and ability to measure current signals between 0-20 mA and voltage signals between 0-10 V. The device is designed on-site and operates using battery power. The finished product is investigated and validated in the laboratory, achieving the required standard with positive results.

Keywords: *the precision multi-channel power supply device, industrial measurement and control*

1. INTRODUCTION

Countries are investing and developing automation in the production process currently. Current loop 4-20mA signals, 0-10V voltage signals have become standard in signal transmission in industrial control systems [1]. These signals comprise control signals for linear valves, sensor transmission signals to the central controller, and control signals for switches.

Consequently, the design of multi-channel standard sources serves the intended function. The control monitoring system plays a crucial role in ensuring the proper functioning of the system. The device has the capabilities of imitating sensor signals by creating a 4-20mA or 0-10V signal source, measuring current and voltage signals, and supplying power to the sensor.

Many manufacturers have launched products to solve this problem, typically: Emin, Keithley, GWInstek, Physical Instruments, devices are manufactured with their own voltage ranges, often serving a certain range of objects, in addition, the cost of each of these products is also very high. In recent studies, the correct power supply is one of the issues that deserve great attention. Examples include research on precision power supplies with superconducting systems [2], temperature-compensated multichannel power supplies for silicon sensors [3], and constant power supplies for inductive loads [4]. Other examples include multi-channel, isolated, and precise current source [5], precision small current source [6], and high-precision multi-channel power source for control system [7].

The development of research on standard equipment used in industry is also in line with the Government's orientation according to Decision 996/QĐ-TTg on " Strengthening innovation in measurement operations to assist Vietnamese businesses in enhancing their productivity" competitiveness and international integration in the period up to 2025, with orientation to 2030". According to the project's objective, at least 100 standard substances, measurement standards, and measuring devices of various types will

be produced by 2025 to address the needs of businesses for precise measurement. To cultivate and enhance the professional experience of at least 10,000 officials engaged in measuring activities. Implement the national set of criteria for evaluating the metrology fields in at least one thousand nationally recognized laboratories for the metrology fields. By 2030, a national metrological infrastructure will be developed that meets the accreditation of at least 300 internationally recognized calibration measurements; the development of at least 250 standard substances, measurement standards, and measuring instruments of all types; the implementation of the Program to ensure the measurement of at least 100,000 businesses; the application of a set of national criteria to evaluate metrology fields; and the establishment of at least 2,000 nationally recognized laboratories for metrology fields.

From the above analysis, the authors propose to research, design and manufacture precise multichannel voltage source and current source equipment including: 01 voltage source channel with operating range from 0-10V, with accuracy $<0.03\%$ rdg; 01 current source channel with operating range from 4-20mA, with accuracy $<0.03\%$ rdg; 01 channel measuring current 4-20mA, accuracy $<0.03\%$ rdg; 01 measuring channel 0-10V, accuracy

< 0.03% rdg. The device has a flexible mechanical design, uses plastic materials, and is easy to process and manufacture. The device has a full range of function keys and input and output pins for channel operation. The test results show that the device works stably and achieves the set targets.

2. EXPERIMENTAL

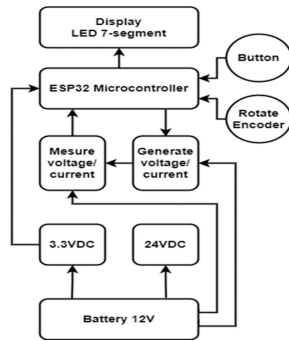

Fig. 1. Overview block diagram of the device

Principle of operation:

- Transmitter mode: The microprocessor will provide a PWM pulse signal to the transmitter according to the set value through the encoder knob and knob. Through the transmitter U&I, the generated current and voltage will be read by the microprocessor through the U&I meter. When the voltage and current readings at the U&I meter are equal to the set value, the microprocessor will automatically control the PWM value to the transmitter accordingly.
- Measurement mode: Apply a voltage or current to the U&I probe, then

the microprocessor will read the value again. The measured values will be displayed on the 7-segment LED.

In addition to measuring and generating 4-20mA current, 0 - 10VDC voltage, the instrument is also capable of providing independent 24VDC voltage for sensor testing.

2.1. The power supply block design

The power supply is designed with the purpose of providing voltage and current for the modules on the circuit to operate continuously, stably and accurately.

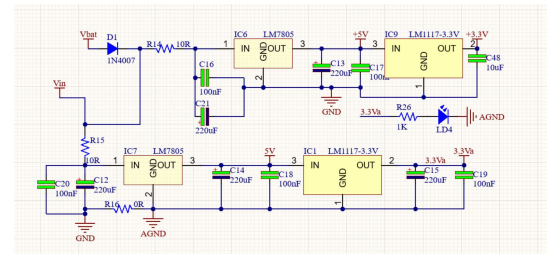

Fig. 2. Power supply circuit diagram

Specifically, the circuit's power supply requires a voltage rating of 5V or 3.3V and sufficient current to power the chip and peripherals. After consulting the power blocks based on the technical requirements of the circuit, we decided to choose the LM7805 power IC that can generate a voltage of 5V and provide a current of up to 1.5A. The voltage takes place from the 12V battery input, through a 5V voltage source, then through the LM1117-3.3V power IC to generate a voltage of 3.3V and provide a maximum current of 500mA. From the

12V input source through 2 ICs LM7805 and 2 ICs LM1117-3.3V to create two separate sources, one analog source just to supply analog ICs, the other to supply microcontrollers and other devices. Digital IC. Similarly, the ground is also divided into two parts like the source to prevent interference for analog ICs. Led LD4 is used to indicate the source when a voltage of 12V is supplied to the circuit.

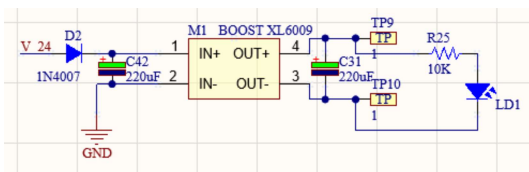

Fig. 3. The 24V power source circuit diagram

Figure 3 depicts the schematic of the power supply circuit, which supplies 24V power to external devices. With a 12V input voltage and the Boost XL6009 circuit, it generates 24V with a 10W capacity and up to 94% efficiency. Can provide a maximum of 4A of current. When 24V power is permitted, the led LD1 illuminates.

The buttons SW1, SW2, SW3, and SW5 are used to select the circuit's functions, as shown in Figure 4.

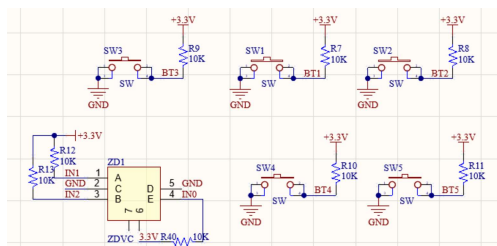

Fig. 4. Diagram of push buttons

2.2. The central processing unit design

The central processing unit, or microcontroller block, is the main processing block of the circuit, performing data processing, connecting the peripherals through communication standards, communication standards. To meet the requirements, the ESP32 microcontroller is selected. The central block uses the UART serial communication protocol to program the ESP32 microcontroller, the external ADC IC uses I2C to communicate with the ESP32.

a. Microcontroller block

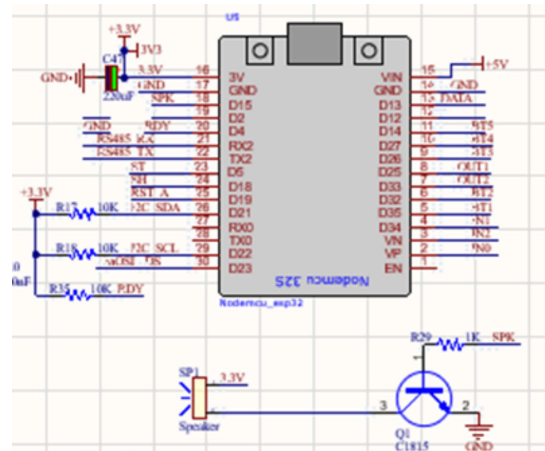

Fig. 5. Block diagram of microcontroller

In this design, the ESP32 microcontroller is selected as the central processor with low energy consumption, low cost, support for Wifi and dual-mode Bluetooth. The microcontroller uses a voltage of 3.3V with a dedicated power supply from the input power source. The power pins of the chip are

further connected to the input capacitors to ensure a stable current.

b. External ADC block

In the design, the authors selected IC ADS1219IPWR with operating voltage range from 2.3V to 5.5V. Equipped with a 24-bit ADC and has a very fast sampling rate of 1000 times/s. To communicate with the microcontroller, ADS1219IPWR uses I2C communication protocol with a transfer rate of up to 1Mbps, there are 16 different I2C addresses. The ADS1219IPWR has 4 inputs/outputs for signal conversion with an accuracy of $\pm 0.5\text{mV}$.

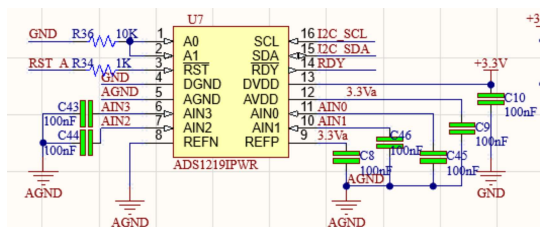

Fig. 6. External ADC block diagram

Since the current signals are in the range of 4-20mA, they need to be amplified. Through the selection process, IC INA128 met the requirements well. To ensure that the IC INA128 works well, the authors use the IC ICL7660 to generate a voltage of -5V for the operation of the IC INA128 and will power it from -5V to 12V to ensure the IC works well.

In voltage measurement mode, the input voltage will be biased to lower the

voltage because the ADS1219IPWR has an input voltage at the AINx pins between -3.4V and 3.4V. So that, we choose resistor values to get voltages in that range and add capacitors to remove noise components.

In current measurement mode, the input current of 4-20mA is converted to voltage by passing it through a 1.8Ohm resistor. The voltage will be amplified with the INA128 IC, which has a gain factor of 51x. The output of IC INA128 will be connected to the input of IC ADS1219IPWR.

In voltage/current mode, the microcontroller connects to the IC 74HC245 to buffer the current because the current from the microcontroller is not large enough. The output of the IC 74HC245 generates 2 PWM pulses. These two PWM pulses are connected to the boost circuit to generate the desired voltage. For current generation mode, the boost circuit will be connected to a 100Ohm resistor to produce a current between 4-20mA. In current generation mode, the output voltage of the boost circuit will be voltage divided and then passed through the IC INA128 with an amplification factor of 3.27 times to create a voltage in the range of 0-10V. These voltages and currents are all feed back to the microcontroller through IC ADS1219IPWR to adjust to the set value.

c. LED display block

Figure 7 is a block diagram of the 7-segment LED display to help display voltage/current values in different modes.

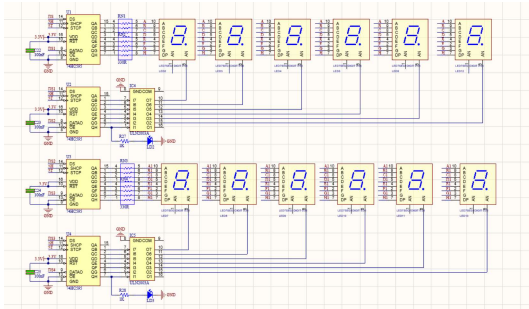

Fig. 7. LED display block

To control the 7-segment LEDs, the microcontroller will transmit data to the IC 74HC595 using the DS pin. By connecting two pins, DS and DATA0, four IC 74HC595 will be connected. The microcontroller will send 24 bytes of data, 12 of which will turn on or off 12 LED 7 bars. There are 12 bytes remaining to display the value on 12 LED 7 bars. To turn on/off the 7-segment LEDs, the Qx pins of the IC 74HC595 will be connected to the ULN2003 IC to invert the value at the Qx pins because the common anode 7 LEDs are used. Six pins from O2 to O7 of each ULN2003 IC will turn on and off six LED 7 bars. The remaining two 74HC595 ICs are connected to two 330ohm bar resistors to limit the current for the Led 7 bars.

Above are all schematic diagrams of high-precision multi-channel

standard-source transmitters researched and manufactured by the author's group. In the next section, we test and evaluate the accuracy of the product through laboratory calibration equipment.

3. RESULTS AND DISCUSSION

3.1. Test function to measure current and voltage



Fig. 8. Test image of voltage and current measurement function

The test results are as follows:

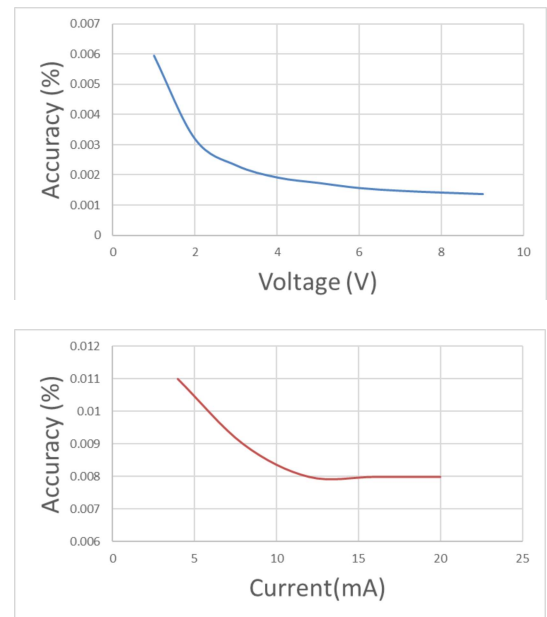

Fig. 9. The graph of device voltage and current measurement accuracy

Functional testing of voltage and current measurement was performed with a multi-purpose reference source FLUKE 5522A in the laboratory according to test procedure QT.02 Multimeter calibration procedure to $5^{1/2}$ digit. The process has been approved by the General Department of Metrology and Quality for implementation. The image of laboratory test measurement on Figure 8.

3.2. Test voltage and current generation function

The voltage and current generation function test was performed by directly measuring the voltage and current from the output device through a Keithley 2002 multimeter with $8^{1/2}$ digits accuracy under laboratory conditions. The procedure performed is QT.12_QT Calibration of current - voltage source.



Fig. 10. Test image of voltage and current generation function

The test results as follows:

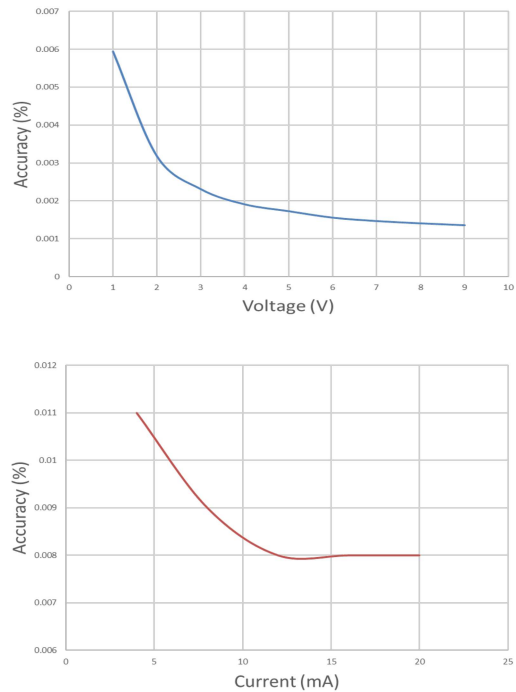

Fig. 11. The graph of device voltage and current generation accuracy

From the test results in Figure 9, 11 shows that, in the functions of measuring and generating voltage and current, the device operates stably and accurately; all measurements at the values in the test range reached the accuracy <0.01 and met the set requirements.

CONCLUSION

The article describes the study, design, and production of precise multichannel voltage and current source equipment, as well as the hardware designs for each functional block. In addition, to evaluate the precision of the product, the authors provide three measurements to assess the capability to generate voltage, current, and

simultaneous transmission of channels.
The obtained results satisfy the specified standards.

ACKNOWLEDGMENT

This research is supported by the National Center for Technological Progress through a Grass-root project contract 16/2022/HĐ-ĐTCS.

REFERENCES

- [1] T. I. Incorporated, "*Patent Issued for Discrete Power Control of Components Within a Computer System (USPTO 10, 365, 704)*," Computers, Networks & Communications, 2019.
- [2] Q. S. Zhang Jianping, "*The working principle and troubleshooting of linear constant voltage and current power supply*," Electronic Test, pp. 108-109, 2017.
- [3] P. F. Y. T. J. L. Z. M. H. M. Jun Qua, "*Research and implementation on high-precision power quality monitoring system of EAST power supply*," in 6th International Conference on Advances on Clean Energy Research, Barcelona, Spain, 2021.
- [4] V. G. A. S. R. D. J. F. C. S. G. R. A. Shukla, "*Multi-channel programmable power supply with temperature compensation for silicon sensors*," Review of Scientific Instruments, vol. 87, no. 1, 2016.
- [5] H. Jinduo, "*Precision adjustable constant current source usable for inductive loads*," Hebei University, 2015.
- [6] G. L. L. G. C. P. Jin Chuanxi, "*A precision micro-current source with nanoamp output*," Nuclear Power Engineering, pp. 117-120, 2016.
- [7] J. Y. P. X. Wen Bo, "*Development of a High Precision Multi-channel Electric Control Pump Signal Monitoring System*," in Journal of Physics: Conference Series, 2020.
- [8] J. L. M. C. P. Chuanxi, "*Design of a Multi-Channel Expandable High-Precision Isolated Current Source Module*," in Journal of Physics: Conference Series, 2021.