



Original Article

Research on the Effect of Human Resource Management on Innovation at Vietnam Electricity Corporation

Nguyen Ngoc Anh*, Dinh Thi Huong

Thuongmai University, No. 79, Ho Tung Mau Road, Cau Giay District, Hanoi, Vietnam

Received: July 15, 2021

Revised: November 10, 2021; Accepted: April 25, 2022

Abstract: This research aims to analyse the effect of human resource management on innovation and creativity at Vietnam Electricity Corporation. Data from 765 questionnaires from Vietnam Electricity Corporation were processed through SPSS software and AMOS 21, then descriptive statistics, exploratory factor analysis (EFA), confirmatory factor analysis (CFA), SEM analysis and a Bootstrap test were performed. The result shows that the factors of human resource management that affect innovation at EVN include: Recruitment of employees and training and development and performance appraisal. Of these, training and development is the factor that has the strongest impact on innovation and creativity at EVN. At the same time, the research also proposes some policy implications for managers at Vietnam Electricity Corporation to promote the activity of human resource management and innovation to enhance the efficiency of its operation.

Keywords: Human resource management, innovation, creativity, Vietnam Electricity Corporation, EVN, Vietnam.

1. Background

Vietnam Electricity Corporation (EVN) has always played a leading role in the investment and development of the power sources and grids, supplying enough electricity for fast, strong and sustainable economic development. The set goal of EVN is to integrate digital technology and a management model suitable with the process of applying digital technology to the corporation's

production and business activities to carry out innovation and increase operational efficiency. The corporation has focused on improving the quality of human resource management activities through recruitment of human resources, training and development, evaluation and total rewards of human resources in the orientation of valuing capacity development and innovation to utilize all resources. This is being achieved through increasing the number of

* Corresponding author

E-mail address: hanna.nguyen2508@gmail.com

<https://doi.org/10.25073/2588-1108/vnueab.4644>

training and fostering programs on new technologies, modern techniques, training talented engineers and information technology, etc. at home and abroad. However, the labour structure by age tends to be mature, affecting labour productivity and the allocation of the labour force to other departments due to different training expertise within the corporation, especially for innovation activities at EVN. As a result, EVN's labour productivity is not high compared to the electricity industry of other countries in the region of equivalent size and the innovation capacity of EVN has not been fully utilised. From the above facts, this paper aims to study the impact of human resource management on innovation at EVN. Thereby, this implies a number of policies for EVN to be autonomous in technology to research, enhance and innovate to improve production and business efficiency.

2. Theoretical framework, hypotheses and research model

2.1. Human resource management, innovation

Human resource management

According to McGuire and Jorgensen [1], human resource management has three main functional groups: Administration: activities that create foundation tools and systems to attract, sustain and ensure the outcome of human resource usage; Development: activities to develop human resource quality and the sustainable connection of people in the organisation; Support: activities that support employers and employees to sustain the foundation for administration and development.

According to Tran Kim Dung [2], human resource management is a system of philosophies, policies and functional activities on attracting, training and development and sustaining people of an organisation to achieve optimal results for both the organisation and its employees. Functions of human resource management include three groups: Human resource attraction (job analysis, human resource planning, recruitment and selection); Training

and development of human resources; Human resource sustenance (compensation, appraisal, labour relations). Thus, human resource management is the combination of administration activities relating to the creation, sustenance, development and effective use of human factors in the organisation to achieve the common goals of the organisation/enterprise.

According to Samma Faiz Rasool et al. [3], a human resource management practice model includes recruitment and selection, training and development, performance appraisal, and compensation and benefits. Functions of human resource management are carried out on a larger scale using smarter methods, providing more comprehensive, intuitive, and timely information for administrative levels and human resource management to support the development and sustenance of human resources.

Innovation

Katz [4] defines innovation as “the creation, development and successful implementation of new and unique ideas including the introduction of products and processes and new development strategies for enterprises, leading to success in business and market leadership achievement, creating value for stakeholders, driving economic growth and raising living standards”.

In this research, we use the definition of innovation in accordance with the standard of the Organisation for Economic Cooperation and Development, in particular, innovation is considered as “the implementation of a new or significantly improved product (goods/service) or process, a new marketing method or a new organisational measure in practical operation, in the organisation of work or in external relations”.

In the OECD Oslo Manual [5], innovation is classified into four types: (i) product innovation, (ii) innovation of operating process, (iii) innovation of management system and (iv) innovation in marketing activities.

2.2. Research hypotheses

Recruitment of employees has a strong impact on the innovation of an organisation/enterprise. Schuler [6] provided

evidence in his research that recruitment and selection affect the value of an organisation/enterprise as this process helps to choose a suitable and capable candidate according to the needs of the organisation/enterprises. In that sense, various enterprises recruit highly qualified and high-quality human resources to bring innovation to the organisation [7]. Thus, recruitment and selection is an important segment of human resource management that helps to stimulate creativity in the organisation. Recruitment of employees and innovation are closely related [8] thereby proposing hypothesis H1:

H1: Recruitment of employees has a positive impact on innovation in enterprise.

Enterprises often have investments in employee training and development, so these investments will produce workers that can make full use of their potential, talent and creative ideas during the work process at the enterprises. Enterprises provide employees with a variety of training and development programs to enhance competencies, improve skills, new knowledge and innovation capabilities required for innovation [9], Rasool et al. [10] contend that training and development have a positive relationship with innovation in organisations. On that basis, the authors of this study propose the following hypothesis:

H2: Training and development has a positive impact on innovation in an enterprise.

The relationship of performance appraisal with innovation of employees is really significant. A number of researchers point out that performance appraisal increases the motivation of employees and the innovation of the organisation [11, 12]. In the process of procedure assessment, performance appraisal of a human resource department must give feedback to employees. In that case, feedback will increase employees' motivation, creative work and innovation in the organisation [7]. Besides, receiving feedback from the human resource department for employees is related to job improvement so that employees can then creatively apply and develop approaches to their

activities. Employees will begin a new method to carry out duties of the organisation [13]. Recruitment and innovation are closely related, thereby proposing hypothesis H3:

H3: Performance appraisal has a positive impact on innovation in an enterprise.

Compensation and benefits are important activities of human resource management and they affect the motivation and behaviour of employees. A good remuneration system will improve the work motivation of employees, bring about a positive attitude at work and innovation in the working process at an organisation. Enterprises need to design attractive compensation and benefits packages to attract skilled employees. Such skilled employees create competitiveness and strong development in an organisation [14]. Therefore, compensation and benefits impact the motivation of employees, so increasing the participation and contribution of employees in the innovation process of the organisation [15]. Therefore, the authors propose the following hypothesis:

H4: Total rewards have a positive impact on innovation in an enterprise.

2.3. Research model

From the four hypotheses of the research model on the impact of human resource management on innovation in EVN, the research model proposes four independent variables including: recruitment of employees, training and development, performance appraisal and total rewards. One dependent variable is innovation. In addition, through expert interviews and practical research at EVN, the authors propose one control variable; i.e. the qualification of employees (see Figure 1). The scale is a 5-point Likert scale: 1 being completely disagree and 5 being completely agree. In particular:

The recruitment of employees factor is coded from RE1→RE4 with four observed variables: RE1- Determining the right number and type of human resources to meet job

requirements; RE2 - Attracting a diverse source of candidates through recruitment news; RE3 - Fast and convenient application collection; RE4 - Selecting the best human resources through recruitment and selection examinations.

The training and development factor is coded from TD→TD5 with five observed variables: TD1 - Professional and technical training and development, TD2 - Political and theoretical training and development, TD3 - Training and development on working methods, TD4 - Training and development on corporate culture; TD5 - Training and development are invested effectively.

The performance appraisal PA is coded from PA1→PA6 with six observed variables: PA1 - Provide feedback to employees on how well they are performing against model standards and with other employees; PA2 - Adjusting and correcting mistakes in the working process of employees; PA3 - Stimulating and motivating employees through evaluation, recognition and support provisions; PA4 - Providing information as a basis for training, salary, rewards, employee transfer, organisational structure improvement; PA5 - Developing business understanding through a conversation about opportunities and career planning; PA6 - Strengthening good relations between superiors and subordinates.

The total rewards of human resources are coded from TR1→TR5 with five observed variables: HRP1 - Total rewards motivate and stimulate employees to work with the highest efficiency, TR2 - Improving quality and business performance of enterprises, TR3 - Contributing to maintaining stable, high-quality and creative human resources for enterprises, TR4 - Helping to improve the efficiency of other human resource management functions in enterprises, TR5 - Maintaining stable and quality human resources for society.

The innovation scale is coded from IB1→IB5 with five observed variables: IB1-Improvement in the process towards digitalisation; GI2 - Improvement in the production of quality products, IB3 - Improvements in the production of products to

save energy and reduce pollution; IB4 - Innovation in providing quality products that are environmentally friendly; IB5 - Innovating a flexible and pioneering way of organizing activities.

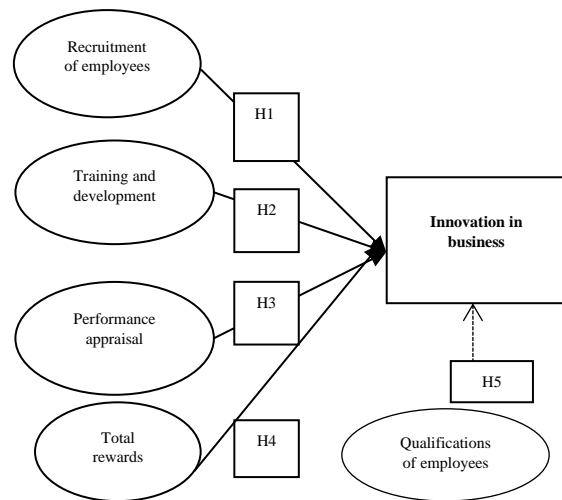

Figure 1: Proposed research model
Source: Summary and recommendation of authors.

Thus, the research model has a total of 25 observed variables in which four independent variables are the recruitment of employees (RE), training and development (TD), performance appraisal (PA), and total rewards (TR). One dependent variable is innovation in business (IB), and one control variable is qualifications of employees (LW).

3. Research method

The research is conducted through quantitative and qualitative steps with two different groups of survey subjects which includes: experts and managers at some units of EVN; managers and employees at enterprises.

From the synthesised theoretical basis, the observed variables are built on a 5-point Likert scale (from 1 being strongly disagree to 5 being strongly agree) reflecting five complete research concepts. Qualitative research through in-depth interviews with eight experts with knowledge of human resource management, innovation and

creativity at units of EVN to supplement and adjust the aforementioned observed variables for better understanding and to be more suitable to the context of EVN. The qualitative research results help to form a quantitative questionnaire consisting of 25 observed variables reflecting four independent variables: recruitment of employees, training and development, performance appraisal and total rewards. One dependent variable is innovation at EVN, a control variable is the qualifications of employees.

There are 25 observed variables in the research, thus the minimum sample is $25 \times 5 = 125$. To ensure representativeness, the sample size is 820, being employees and managers working at subsidiaries of EVN. The author's sampling method is non-probability random sampling. The sample size of the research is divided equally into the norm for each manufacturing enterprise. The survey objects were approached using two methods: (i) Sending the designed survey on Google docs to the email address of employees and managers at manufacturing enterprises; (ii) Sending surveys directly to employees and managers at Vietnamese manufacturing enterprises. After screening the answer sheets, 65 invalid votes were removed (due to missing information) and 765 valid votes remained, which the authors used for data entry and data processing. Of these, 216 votes were from managers, 549 valid votes were from employees at the EVN. This data was then imported into an Excel file, then analyzed by SPSS and AMOS 21 software. In particular, SPSS software is used to analyse descriptive statistics and analyse the reliability of Cronbach's Alpha. AMOS software was used for exploratory factor analysis, and confirmatory factor analysis. SEM linear structure analysis and a Bootstrap test were applied.

4. Research results

4.1. Characteristics of the research sample

Out of 765 questionnaires collected from subsidiaries of EVN, 87.19% are male

employees and the remaining 12.81% are female employees since the industry's specificity is a high-risk environment with many potential unsafe factors. It can be seen that the number of employees with university and postgraduate degrees is 64.97% following by a college degree with 7.109% and a vocational school with 26.01%. The remainder of the workforce has other qualifications. This shows that the number of employees of EVN who have qualifications to meet the job requirements are increasing. Besides, the employees' incomes are more stable and are consistent with the increase in labour productivity and the State's salary regime with an average labour income of over 12 million VND, which is received by 62,09% of the employees.

4.2. Testing the reliability of the scale

(i) The reliability of recruitment of employees scale: Variables in the scale RE have Cronbach's Alpha coefficient = $0.818 > 0.6$, which ensures high reliability. The smallest Corrected Item Total Correlation coefficient reaches $0.513 > 0.3$, showing that observed variables can all be used for exploratory factor analysis.

(ii) The reliability of training and development of human resources scale: Variables in the scale TD have Cronbach's Alpha coefficient = $0.792 > 0.6$ which ensures high reliability. The smallest Corrected Item Total Correlation coefficient reaches $0.457 > 0.3$, showing that observed variables can all be used for exploratory factor analysis.

(iii) The reliability of performance appraisal scale: Variables in the scale PA have Cronbach's Alpha coefficient = $0.802 > 0.6$ which ensures high reliability when removing PA6. The smallest Corrected Item Total Correlation coefficient reaches $0.516 > 0.3$, showing that observed variables can all be used for exploratory factor analysis.

(iv) The reliability of total rewards of human resources scale: Variables in the scale TR have Cronbach's Alpha coefficient = $0.751 > 0.6$ which ensures high reliability. The smallest

Corrected Item Total Correlation coefficient reaches $0.433 > 0.3$, showing that observed variables can all be used for exploratory factor analysis.

(v) The reliability of innovation scale: Variables in the scale IB have Cronbach's Alpha coefficient = $0.783 > 0.6$ which ensures high reliability. The smallest Corrected Item Total Correlation coefficient reaches $0.426 > 0.3$, showing that observed variables can all be used for exploratory factor analysis.

4.3. The results of exploratory factor analysis

Table 2: Pattern matrix

	Factor				
	1	2	3	4	5
TD5	.763				
TD4	.702				
TD2	.644				
TD1	.636				
TD3	.519				
PA2		.888			
PA5		.704			
PA3		.684			
PA1		.522			
RE3			.774		
RE2			.689		
RE1			.620		
RE4			.560		
IB3				.723	
IB1				.636	
IB4				.629	
IB2				.628	
TR4					.831
TR5					.751
TR3					.623

Source: Synthesized results from the analysis of SPSS 21.

The results of exploratory factor analysis (after 2 runs) gave the results of 20 observation variables grouped into five factors named respectively, which are shown in Table 2: Training and development (TD5, TD4, TD2, TD1, TD3); performance appraisal (PA2, PA5,

PA3, PA1); recruitment of employees (RE3, RE2, RE1, RE4); innovation (IB3, IB1, IB4, IB2), total rewards (TR4, TR5, TR3). Observed variables: TR1, IB5, TR2, with weight < 0.5 do not satisfy the condition, so they are excluded from the model.

4.4. The results of confirmatory factor analysis

The results of analysing confirmatory factor show that the model has 252 degrees of freedom. Chi-squared = 378.046 with $p = .000$. Other indicators: Chi-squared/df = 2.363, GFI, TLI, CFI are all higher than 0.9 [16], RMSEA = $0.055 < 0.08$ [20] (see Figure 3), which show that the model is considered to be consistent with market data.

Unidimensionality: Confirmatory factor analysis gave results of Chi-squared = 378.046 with $p = 000$. Other indicators: Chi-squared/df = 2.363, GFI, TLI, CFI are all higher than 0.9 [19], RMSEA = $0.055 < 0.08$ [17] => This gives a necessary and sufficient condition for the set of observed variables to achieve unidimensionality (18).

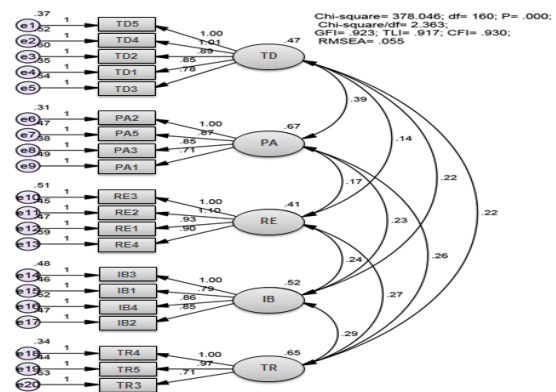

Figure 2: The results of confirmatory factor analysis (standardized)

Source: Synthesized results from the analysis of SPSS and Amos 21.

Convergent validity: For the weights (standardized) all are > 0.5 . This proves that the scale of concepts all achieve convergent validity.

Discriminant validity: The correlation coefficients between the research concepts in the model are all positive and < 1 and different

compared to 1. The P-value is very small and < 0.05, so the correlation coefficient of each pair of concepts is different than 1 at the confidence level of 95%.

4.5. The results of research hypothesis testing

The results of SEM model analysis show that there are four factors of human resources management affecting innovation at EVN

including: training and development, performance appraisal, recruitment of employees and qualifications of employees. These factors are all statistically significant at the 95% confidence level. The regression weights in the table above, all have positive signs, showing that training and development, performance appraisal, recruitment of employees and employee qualifications have a positive influence on innovation at EVN.

Table 3: Regression weights

	Estimate	S.E.	C.R.	P	Label
IB <--- TD	.425	.088	4.568	***	
IB <--- PA	.348	.082	3.671	***	
IB <--- RE	.259	.071	2.376	***	
IB <--- TR	.193	.064	1.582	.102	
IB <--- QE	.126	.056	1.373	.009	

Source: Synthesized results from the analysis of SPSS and Amos 21.

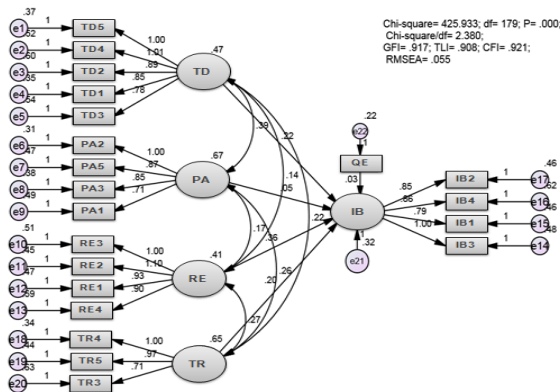

Figure 3: The results of SEM model analysis (standardized)

Source: Synthesized results from the analysis of SPSS and Amos 21.

Out of the four factors, training and development have the strongest impact with the value of the standardized weight of 0.425, followed by performance appraisal with a weight of 0.348, the recruitment of employees with a weight of 0.259 and finally the employee's qualification with the weight 0.126. The linear regression equation shows the relationship

between the variables of human resource management affecting innovation at EVN is as follows:

$$IB = 0.425*TD + 0.348*PA + 0.259*RE + 0.126*QE$$

4.6. Model testing using Bootstrap analysis

Parameter	SE	SE-SE	Mean	Bias	SE-Bias	CR
IB <--- TD	0.105	0.005	0.209	0.006	0.007	0.857
IB <--- PA	0.112	0.006	0.06	0.005	0.008	0.625
IB <--- RE	0.080	0.004	0.319	0.002	0.006	0.333
IB <--- QE	0.051	0.003	0.02	0.003	0.004	0.75

Figure 4: Bootstrap test

Source: Synthesized results from the analysis of SPSS and Amos 21.

Bootstrap is a suitable method to replace [19] the initial sample n = 765, Bootstrap is the

iterative sampling method with substitution where the original sample plays a crowd role.

Looking at the table above, it can be seen that the absolute value of CR is very small compared to 2, so it can be said that the bias is very small, not statistically significant at 95% confidence => The estimates in the SEM model can be trusted.

5. Result discussion and some recommendations

From the linear regression equation on the effect of human resource management on innovation, it can be seen that training and development, performance appraisal, recruitment of employees and innovation in business are four factors that have a significant influence on innovation at EVN, in which training and development of human resources has the strongest impact with a standardized regression weight of 0.425, followed by two factors of performance appraisal and recruitment of employees with a standardized regression weight of 0.348; 0.259 respectively. Finally, the qualifications of employees factor is only 0.126. Hypotheses H1, H2, H3, H5 are accepted and hypothesis H4 is rejected.

This result is consistent with the research results of some authors that consider human resource management (recruitment of employees, training and development, performance appraisal) to have a positive impact on innovation of an organisation/enterprise in which the training and development factor has the strongest impact on innovation at EVN, followed by performance appraisal and recruitment of employees. In addition, the research also identifies the qualifications of employees as the control variable which has an influence on innovation at EVN. The reality at EVN also shows that over the years, with a well-trained workforce, the electricity industry can now handle complex tasks with a high technology skill demand that previously relied entirely on the support of foreign experts. The corporation is also completing the digital ecosystem and forming an EVN database.

Nevertheless, one of the challenges facing EVN's human resources is the lack of decent managers and experts with high technical and technology skills. There is a lack of skilled workers and technicians with technological autonomy who are geared towards research, innovation and creativity to improve production and business efficiency. Through the results of quantitative research and collected data, some recommendations to improve the implementation of human resource management to promote innovation at EVN in the coming time are as follows:

5.1. Further investing in training and development of human resources to promote innovation at EVN

Presently, the training system of EVN includes one university and three colleges. Schools have changed their mechanism, strongly shifting from ability-based training to on-demand training and actively improving training quality. At the moment, schools under EVN are training students in about 30 majors from university-level or below with an enrolment scale of over 15,000 students per year.

EVN urgently needs to transform each member unit into a learning organisation, creating the best conditions for employees to promote their potential creativity. Also, in the current period to 2025, EVN should consider piloting in one of the fields of hydroelectricity, thermal power, management and operation of transmission/distribution lines, management and operation of substation transmission/distribution, etc. to unify technical rank standards and training programs to upgrade the main titles in the production and business chain of EVN.

5.2. Improving the efficiency of performance appraisal to promote innovation at EVN

EVN needs to improve the efficiency of performance appraisal by carrying out a rating system to evaluate employees associated with behavioural competence and skills to perform

green job such as establishing a standard appraisal system associated with the job. On the basis of performance appraisal and training, salary norms and promotion mechanisms are built based on title standards. Even electricity companies in Japan or Korea also perform inspection, testing, and publicizing regimes according to internal inspection and cross-checking processes to form a professional team of employees and officials.

EVN needs to increase employee appraisal through innovation and creativity indicators at work. Examples are included converged infrastructure technology, cloud computing, virtualisation technology, artificial intelligence, big data processing technology, mobile computing technology, IoT, etc.

5.3. Valuing the recruitment process to promote innovation at EVN

Effective recruitment of employees will provide an enterprise with a skilled, dynamic, creative labour force, supplementing adequate human resources for the requirements of EVN's production and business activity in the context of the digital economy and Industrial Revolution 4.0.

In that spirit, recruitment of employees needs to meet the standards of qualifications, high-tech skills, proficiency and workability in the context of the digital economy and Industrial Revolution 4.0. This is the reason why EVN has been focusing on the completion of digital infrastructure with the background on EVN's Cloud system, digital background establishment, AI development, standardization of a database and promotion of automation and research on robot usage to perform heavy and dangerous duties, etc.

5.4. Synchronously implementing a number of other policy implications

Steps that need to be taken: Researching and applying technologies of Industrial Revolution 4.0 on business and production activities of EVN and other Vietnamese enterprises such as

converged infrastructure technology, cloud computing, virtualization, artificial intelligence, big data, mobile computing, IoT, etc. At the same time, focusing on the improvement of the digital infrastructure, which is the foundation of EVN's Cloud system, building a digital platform, developing AI; standardization of databases; promoting automation, researching and using robots to carry out heavy and dangerous works, etc.

Further steps: Increasing operational efficiency of the national innovation system, the innovative startup ecosystem, considering the enterprise as the center; developing new business model, digital economy, digital society; improving the enterprises' abilities to innovate, incorporate and master the technology of the enterprise; focusing on the development of high technology, key technologies of IR 4.0 with high applicability. Along with that, set up pillars to strengthen the link between Institutes - Universities - Enterprises, promoting technology commercialization, effectively exploiting intellectual property, thereby forming innovative start-ups with strength on intellectual and resources for rapid breakthrough, etc.

6. Conclusion

Implementing human resource management, innovation and creativity at the EVN are one of the matters that need to be done not only on the level of enterprises, but also on the local, sectoral and national levels. The research has established and tested the impact model of human resource management on innovation at EVN. The result shows that the factors of human resource management that affect innovation in public organisations in Vietnam include recruitment of employees, training and development, performance appraisal and qualifications of employees, in which training and development is the factor that has the strongest impact on innovation at EVN. On the basis of the research results, there are some implications for solutions to improve the implementation of human resource management

in order to promote EVN's innovative activities from further investment in training and development of employees to promote innovation, valuing recruitment of employees and its impact on innovation at EVN as well as synchronously implementing a number of policy implications to promote innovation.

References

- [1] McGuire and Jorgensen, *Human Resource Development: Theory and Practice*, Sage, 2011.
- [2] Dung, T.K., *Human Resource Management*, Statistical Publishing House, Hanoi, 2011.
- [3] Samma Faiz Rasool et al., "Pharmaceutical Lemons: Innovation and Regulation in the Drug Industry," *Michigan Telecommunications and Technology Law Review*, 14 (1) (2019) 1-41.
- [4] Katz, B., "The Integration of Project Management Processes with a Methodology to Manage a Radical Innovation Project," Diss. Stellenbosch: University of Stellenbosch, 2007.
- [5] Manual, O., "The Measurement of Scientific and Technological Activities," *Proposed Guidelines for Collecting an Interpreting Technological Innovation Data*, 30 (2005) 1-162.
- [6] Schuler, R. S., "Strategic Human Resource Management and Industrial Relations," *Human Relations*, 42 (2) (1989) 157-184.
- [7] Shipton, H., West, M.A., Dawson, J., Birdi, K. and Patterson, M., "HRM as a Predictor of Innovation," *Human Resource Management Journal*, 16 (1) (2006) 3-27.
- [8] Boselie, P., Dietz, G., & Boon, C., "Commonalities and Contradictions in HRM and Performance Research," *Human Resource Management Journal*, 15 (3) (2005) 67-94.
- [9] Chen, C.-J., & Huang, J.-W., "Strategic Human Resource Practices and Innovation Performance - The Mediating Role of Knowledge Management Capacity," *Journal of Business Research*, 62 (1) (2009) 104-114.
- [10] Rasool, S.F., Samma, M., Wang, M., Zhao, Y. and Zhang, Y., "How Human Resource Management Practices Translate into Sustainable Organizational Performance: The Mediating Role of Product, Process and Knowledge Innovation," *Psychology Research and Behavior Management*, 12 (2019) 1009-1025.
- [11] Asif, M., Zhiyong, D., Faiz Rasool, S., & Aftab Madni, M., "Analysis of Motivation Level of L2 Learners in Enhancing Speaking Skill," *European Online Journal of Natural and Social Sciences*, 8 (3) (2019) 584-593.
- [12] Egan, T. M., "Factors Influencing Individual Creativity in the Workplace: An Examination of Quantitative Empirical Research," *Advances in Developing Human*, 7 (2) (2005) 160-181.
- [13] Jiang, J., Wang, S., & Zhao, S., "Does HRM Facilitate Employee Creativity and Organizational Innovation? A Study of Chinese Firms," *The International Journal of Human Resource Management*, 23 (19) (2012) 4025-4047.
- [14] Farooq, M., Ullah, I., & Hameed, R. M., "HR Practices and Organizational Innovation: the Mediating Role of Knowledge Management Effectiveness," *Journal of Social and Development Sciences*, 7 (3) (2016) 50-67.
- [15] Lepak, D. P., Liao, H., Chung, Y., & Harden, E. E., "A Conceptual Review of Human Resource Management Systems in Strategic Human Resource Management Research," *Research in Personnel and Human Resources Management*, 25 (2006) 217-271.
- [16] Bentler, P.M. and Bonett, D.G., "Significance Tests and Goodness of Fit in the Analysis of Covariance Structures," *Psychological bulletin*, 88 (3) (1980) 588.
- [17] Steiger, J.H., "A Note on Multiple Sample Extensions of the RMSEA Fit Index," *Structural Equation Modeling: A Multidisciplinary Journal*, 5 (4) (1998) 411-419.
- [18] Steenkamp, J.B.E. and Van Trijp, H.C., "The Use of LISREL in Validating Marketing Constructs," *International Journal of Research in Marketing*, 8 (4) (1991) 283-299.
- [19] Anderson, J.C. and Gerbing, D.W., "Structural Equation Modeling in Practice: A Review and Recommended Two-step Approach," *Psychological Bulletin*, 103 (3) (1988) 411.