

PERFORMANCE IMPROVEMENT OF CORE GMPLS NETWORKS USING 2-D CODE LABEL AND OPTICAL HARD-LIMITERS

Dang The Ngoc, Nguyen Tien Ban

Faculty of Telecommunications, Posts and Telecommunications Institute of Technology

Corresponding author: *ngocdt@ptit.edu.vn; bannt@ptit.edu.vn*

Received 15 November, 2011

ABSTRACT

The standard core GMPLS networks consist of two layers, Fiber Switch Capable (FSC) and Wavelength Switch Capable (LSC). To extend the core switch capacity, code switch capable (CSC) layer has been added. The CSC layer, however, induces the complexity of the networks. In this paper, we propose a novel scheme of two-dimensional (2-D) optical code label for core GMPLS networks. In our proposal, the LSC layer and CSC layer are combined into one, i.e., 2-D CSC layer. The complexity of the GMPLS networks is therefore reduced while the core switch capacity is still enhanced. In addition, to mitigate multiple-access interference (MAI), we propose to use optical hard-limiters (OHLs) at the core switches. Numerical results show that the throughput is increased significantly and able to reach the peak value.

Keywords. GMPLS networks, optical code label, optical hard-limiters.

1. INTRODUCTION

Multi-Protocol Label Switching (MPLS) is a technique for setting up a specific path for a given sequence of packets [1]. By labeling every packet, a routing table does not have to be referred in order to figure out which outward path a packet should be switched toward its destination. MPLS is called multiprotocol because it works with the Internet Protocol (IP), Asynchronous Transport Mode (ATM), and frame relay network protocols. In addition to moving traffic faster, MPLS makes it easier to manage a network for quality of service (QoS).

GMPLS (Generalized Multi-protocol Label Switching), also known as Multiprotocol Lambda Switching, is a technology that provides enhancements to MPLS to support network switching for time, wavelength, and space switching as well as for packet switching [2, 3]. In particular, GMPLS will provide support for photonic networking, also known as optical communications.

The current standards for GMPLS [4], which is shown in Fig. 1a, define five label mapping spaces; namely Packet Switch Capable (PSC), Layer 2 Switch Capable (L2SC), Time-slot Switch Capable (TSC), Wavelength Switch Capable (LSC), and Fiber Switch Capable (FSC).

Only the last two layers (LSC and FSC) can be utilized in an all-optical switching device. The remaining label mapping spaces require optical-to-electrical conversion, which negatively impacts switching speed.

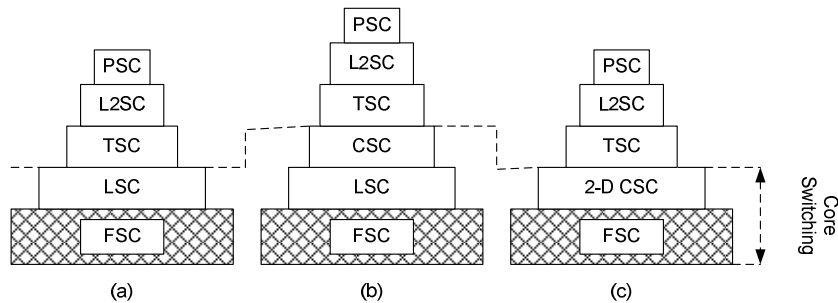

Figure 1. Label mapping layers in GMPLS networks

To further enhance the benefits of the label mapping technique in the all-optical domain and increase the label space, Code Switch Capable (CSC) layer using one-dimensional (1-D) code has been added in between the TSC layer and the LSC layer (Fig. 1b) [5],[6]. This solution, however, has limitations. With an additional layer, the control plane will be more complex. In addition, like optical code-division multiple-access systems, multiple-access interference (MAI) is a critical issue which affects on the performance of optical code labeled core GMPLS networks [6].

In this work, we propose a novel scheme of two-dimensional (2-D) code label for core GMPLS networks. 2-D code, which consists of a time spreading pattern and a wavelength hopping pattern [7], helps to combine the LSC and CSC layers into 2-D CSC layer as shown in Fig. 1c. The complexity of the GMPLS networks is therefore reduced while the core switch capacity is still enhanced. In addition, 2-D code outperforms optical orthogonal code (OOC), which was used in [6], in terms of both cardinality and cross-correlation. Moreover, to mitigate MAI, we propose to use optical hard-limiters (OHLs) at the core GMPLS switches. We also derive mathematical models for the performance of the proposed core switch. The performance is measured in terms of core switch capacity, probability of error, and core switch throughput.

The rest of the paper is organized as follows. Section 2 presents the architecture of the proposed core GMPLS switch. The construction of 2-D prime code is presented in Section 3. Performance analysis of the core switch is presented in Section 4. Section 5 shows the numerical results and discussion. Finally, Section 6 concludes the paper.

2. PROPOSED GMPLS CORE SWITCH ARCHITECHTURE

Figure 2 shows the architecture of the GMPLS core switch, which is capable of performing optical label switching using two label switching layers (FSC and 2-D CSC). The switch consists of four main parts; the Optical Cross-Connect (OXC) backplane, the all-optical input module, the all-optical output module, and the electrical control unit.

The all-optical input module includes a fiber de-multiplexer that allows separating incoming fibers into different ports of the switch. The output of each single fiber is fed into a splitter, which splits the signal through a rack of N different 2-D decoders. Each 2-D decoder is matched to one of the N different 2-D codes, whose code weight is K . To mitigate MAI, at each

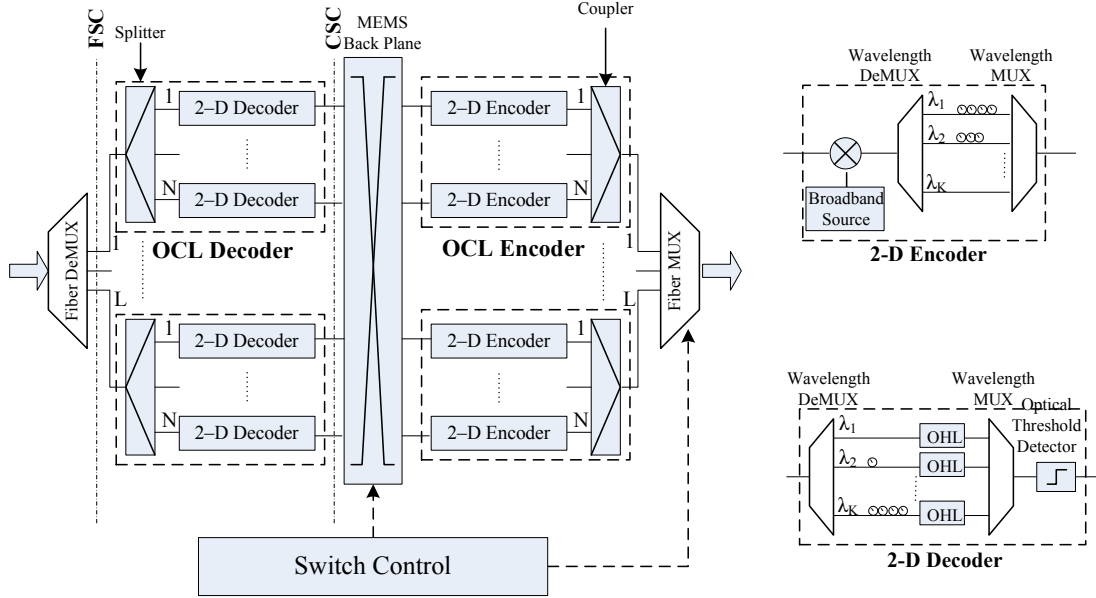

Figure 2. Architecture of core GMPLS switch using 2-D code label

2-D decoder we propose to use an OHL at each wavelength so that only a maximum of one pulse can pass through it. The decoder also has an associated threshold detector, which only passes light if the total energy of the pulse is above a certain value. The rack of 2-D decoders, combined with the optical splitter at the input, is called the Optical Code Label (OCL) decoder.

The all-optical output module performs the reverse of the above operation. It starts with an OCL encoder that has the same structure of the OCL decoding unit, except that it consists of N 2-D encoders. The outputs of the 2-D encoders within each OCL encoder are combined using a coupler. Finally, the signals are distributed into the different fibers using the fiber multiplexer.

The electrical control unit, in conjunction with the OXC core, function as the heart of the switch. The control unit basically performs the label switching operation by making sure that the OXC is configured in a manner that switches incoming flows belonging to a certain Label Switched Path (LSP) to their corresponding output Forward Equivalent Class (FEC). The control unit also maintains the label lookup table, and receives and sends necessary signaling and control data for GMPLS network configuration and maintenance using the dedicated signaling and control labels.

3. 2-D PRIME CODE

A 2-D codeword is the combination of a time-spreading (TS) pattern and a wavelength-hopping (WH) pattern. In this paper, we use prime code for both patterns. A TS pattern can be generated using the linear congruent placement operator, to place a pulse within a block as follows:

$$a_{xy} = [x, y] \quad x, y = 0, 1, \dots, p_s - 1, \quad (1)$$

where p_s is a prime number, and $[\cdot]$ denotes modulo p_s operation [7]. The algorithm determines the place of a pulse within a block of length p_s . A code pattern consisting of p_s such blocks. Similarly, a WH pattern is generated from a prime number p_h ($p_s \leq p_h$). The process of generating the TS and the WH patterns is illustrated in Table 1.

The WH pattern H_0 comprises pulses at one wavelength only, as evident from Table 1, and is therefore discarded. Hence the number of WH patterns is $p_h - 1$, the number of TS patterns being p_s . Thus a 2-D code set, including $p_s(p_h - 1)$ distinctive 2-D prime codewords of length $F = p_s^2$, can be generated. The code weight is $K = p_s$ and the maximum cross-correlation between two 2-D codewords is one [7]. An example of 2-D prime codeword that is constructed from S_0H_1 is $\lambda_00000 \lambda_10000 \lambda_20000 \lambda_30000 \lambda_40000$.

Table 1. WH And TS patterns for $p_s = p_h = 5$

WH pattern		TS pattern		
H_0	$\lambda_0\lambda_0\lambda_0\lambda_0\lambda_0$	S_0	10000	10000 10000 10000 10000
H_1	$\lambda_0\lambda_1\lambda_2\lambda_3\lambda_4$	S_1	10000	01000 00100 00010 00001
H_2	$\lambda_0\lambda_2\lambda_4\lambda_1\lambda_3$	S_2	10000	00100 00001 01000 00010
H_3	$\lambda_0\lambda_3\lambda_1\lambda_4\lambda_2$	S_3	10000	00010 01000 00001 00100
H_4	$\lambda_0\lambda_4\lambda_3\lambda_2\lambda_1$	S_4	10000	00001 00010 00100 01000

4. PERFORMANCE ANALYSIS

4.1. Core Switch Capacity

Core switch capacity is defined as the maximum number of optically isolated or identifiable flows that the networks can carry [6]. For a DWDM (Dense Wavelength Division Multiplexing) network that uses L fibers for FSC layer and M wavelengths for LSC layer, the capacity, C^{F-L} , can be expressed as [6]

$$C^{F-L} = L \times M . \quad (2)$$

For the GMPLS network that employs L fibers for FSC layer, M wavelengths for LSC layer, and N codewords for CSC layer, the capacity is written as $C^{F-L-C} = L \times M \times N$. In the case that optical orthogonal code (OOC) is used for CSC, C^{F-L-C} can be calculated as [6]

$$C^{F-L-C} = L \times M \times \left\lfloor \frac{F-1}{K(K-1)} \right\rfloor, \quad (3)$$

where F and K is the code length and code weight of the OOC code, respectively.

For our proposed GMPLS network that uses L fibers for FSC layer and 2-D prime codes for CSC layer, the capacity (C^{F-C}) is the product L and the number of 2-D codewords per fiber. C^{F-C} therefore can be expressed as

$$C^{F-C} = L \times N_{2D} = L \times p_s (p_h - 1), \quad (4)$$

where N_{2D} is the cardinality of a 2-D prime code set that is constructed from two prime numbers, p_s and p_h .

4.2. Probability of Errors

The probability of error, P_e , is a key parameter that determines the transmission mechanism quality. Also, to estimate the core switch overall throughput, the probability of error needs to be calculated. In order to make a fair comparison, we employ the same assumption with previous works [5],[6]. It means that we only focus on the effect of MAI on the network performance, the effects of noise, dispersion, and other physical layer impairments are ignored. Another important assumption is that the encoding and decoding of the spread spectrum optical signals are performed in a bit synchronous manner. This means that time elapses in steps of chip duration and the transmitter and receiver are perfectly synchronized.

Each 2-D decoder receives the signal from not only the targeted source but also from $N - 1$ remaining sources, where N are the number of codewords. A given source can be in one of the following two states: transmitting a logical '1' with probability p_1 and transmitting a logical '0' with probability $p_0 = 1 - p_1$. At the 2-D decoder, a logical '0' is detected if the total number of optical pulses is smaller than the threshold H ($H \leq K$) otherwise a logical '1' is detected. An error happens in the case that the targeted source sends bit '1' however the decoder detects bit '0' ($P(0/1)$) or vice versa ($P(1/0)$). The total probability of error hence can be expressed as

$$P_e(N) = p_1 P(1/0) + p_0 P(0/1). \quad (5)$$

When the targeted source sends bit '1', the total number of optical pulses appearing at the input of the threshold detector is K regardless of other sources' states. This is because all K desired pulses of the chip sequence representing the bit '1' will be collected since their relative delays and wavelengths are matched to this decoder. MAI pulses from other sources are blocked by OHLs. As the threshold is set to $H \leq K$, where $K = p_s$ is the code weight of the 2-D prime code, there is no error, i.e., $P(0/1)=0$.

In the case that the targeted source sends bit '0', an error may happen due to MAI from remaining sources that send bit '1'. We assume that, among $N-1$ remaining sources, there are n sources that send bit '1'. n therefore can be modeled as a binomial random variable with a probability p_1 .

As the cross-correlation between any two 2-D prime codes is at most one, the maximum number of MAI pulses at the input of the considered decoder is n .

These MAI pulses are distributed over K wavelengths. Let n_i , $i = 1$ to K , denote the number of MAI pulses at the i -th wavelength; then n_i is a random variable whose value is in the range of 0 and n ($n = \sum_{i=1}^K n_i$). At the output of an OHL, there is a pulse at the i -th wavelength only when $n_i \geq 1$ [11]. The total number of pulses at the input of the threshold detector, denoted as n_H , will be in the range of 0 and K . An error happen if $n_H \geq H$. $P(1/0)$ therefore can be calculated as

$$P(1/0) = \sum_{n=1}^{N-1} \binom{N-1}{n} p_1^n (1-p_1)^{N-1-n} \Pr\{n_H \geq H\} = \sum_{n=1}^{N-1} \binom{N-1}{n} p_1^n (1-p_1)^{N-1-n} \sum_{n_H=H}^K \Pr\{k = n_H\}, \quad (6)$$

where k is a random variable representing the number of MAI pulses at the input of the threshold detector. $\Pr\{k = n_H\}$ is the probability that there are totally n_H MAI pulses. It is therefore equal to the probability that the number of wavelengths, at which the number of MAI pulses (at the input

of the OHL) is different from zero (i.e., $n_i \geq 1$), is n_H . It is also equivalent to the probability that the number of MAI pulses is empty at $\overline{n_H} = K - n_H$ wavelengths. Employing the model of the occupancy problem [8] $\Pr\{k = n_H\}$ can be calculated as

$$\Pr\{k = n_H\} = \sum_{l=n_H}^K (-1)^{l-n_H} \binom{K}{l} \left(\frac{l}{n_H}\right) (1-lp_\lambda)^n, \quad (7)$$

where p_λ is the probability that a pulse from one user becomes a MAI one and is visible at one of K wavelengths.

For 2-D prime code, p_λ can be calculated as $p_\lambda = \langle \mu_\lambda \rangle / p_s^3$, where $\langle \mu_\lambda \rangle$, the average number of wavelengths common to any pair of codes, can be estimated as [9]

$$\langle \mu_\lambda \rangle = \frac{1}{\binom{p_h}{p_s}} \left\{ \binom{p_h-1}{p_s-1} \frac{(p_s-1)(p_s-2) + (p_h-2)}{(p_h-2)} + \binom{p_h-1}{p_s} \frac{p_s(p_s-1)}{(p_h-2)} \right\}. \quad (8)$$

4.3. Core Switch Throughput

Core switch throughput, $S(N_f)$, is defined as the expected number of successful packet transmissions per unit time conditioned on the total number of input flows, N_f , offered to the system [10]. If we assume that packets have a fixed length of X bits and that bit errors are independent from one bit to the other, the throughput expression can be achieved by

$$S(N_f) = N_f (1 - P_e)^X. \quad (9)$$

For a switch using DWDM switching with M wavelengths and fiber switching with L fibers, the throughput expression can be expressed as [10]

$$S^{F-L}(N_f) = \begin{cases} N_f & \text{if } N_f \leq L \times M \\ L \times M & \text{if } N_f > L \times M \end{cases}. \quad (10)$$

The throughput expression for an 1-D OCDMA system over a single-fiber, single-wavelength channel, given the number of flows, F , per wavelength per fiber, can be achieved by [6]

$$S(F) = \begin{cases} F [1 - P_e(F)]^X & \text{if } F \leq N \\ N [1 - P_e(N)]^X & \text{if } F > N \end{cases}, \quad (11)$$

where $F = N_f / (L \times M)$ with the assumption that N_f is equally distributed among the different fibers and wavelengths. Consequently, the overall throughput in this case, i.e., L fibers with M wavelengths per fiber, is given by

$$S^{F-L-C}(N_f) = L \times M \times S(F). \quad (12)$$

In the case of using 2-D code label, 2-D CSC layer is deployed directly above FSC layer, the throughput hence can be calculated as

$$S^{F-C}(N_f) = L \times S(F), \quad (13)$$

where the number of flows per fiber $F = N_f / L$ with the assumption that N_f is equally distributed among the different fibers.

5. NUMERICAL RESULTS

In this section, we compare the core switch capacity and throughput of our proposed GMPLS networks using 2-D code label to that of the GMPLS networks using OOC label. We choose code length as a background for the comparison. As code length governs the optical pulse width, it will be identical in the case that 2-D code and OOC have the same code length. Therefore, this is a fair comparison, even when the effects of fiber dispersion and nonlinear effects are taken into account.

We have used the number of fibers $L = 4$ and the number of wavelengths $M = 31$. We assume that the source is symmetric, with equal probability for producing a '1' or a '0' bit, resulting in $p_1 = p_0 = 1/2$. The total number of input flows is $N_f = 2000$ and the packet length is $X = 1024$.

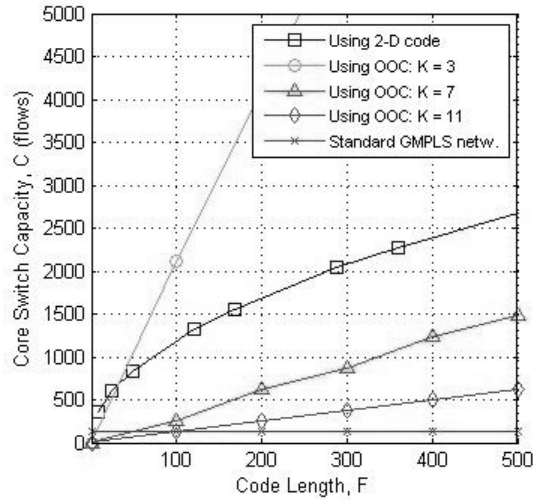

Figure 3. Core switch capacity (C) versus the code length (F) when the number of fibers L is 4 and the number of wavelengths M is 31

Figure 3 and 4 show that the core switch capacity and throughput of the standard GMPLS network is low and independent from the code length as it is equal to the product of L and M . The use of additional CSC layer (either using 1-D OOC or 2-D prime code label) is able to significantly enhance both the capacity and throughput, especially when the code length is large.

For the GMPLS networks using OOC label, the code weight is expected to be small in order to have large core switch capacity. Figure 3 shows that, to achieve larger core switch capacity than that of our proposed GMPLS networks, the GMPLS networks using OOC label have to reduce the code weight to 3. However, when the code weight is too small, the effect of MAI is severe. As a result, the core switch throughput is much lower than the expected value of 2000 as shown in Fig. 4.

Figure 4 also shows that the core switch throughput of our proposed GMPLS networks is much larger than that of both the standard GMPLS networks and the GMPLS networks using OOC label. For example, when the code length is 300, the core switch throughput of our proposed GMPLS networks is able to achieve the peak value of 2000 while the throughput of the standard GMPLS networks and the GMPLS networks using OOC label are only 124 and 1000, respectively.

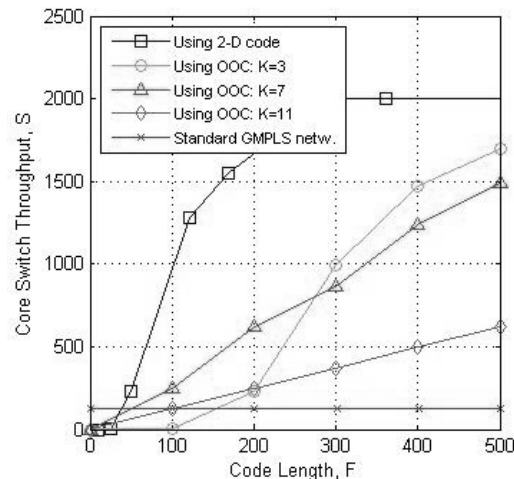

Figure 4. Core switch throughput (S) versus code length (F) when the number of input flows (N_f) is 2000 and the packet length (X) is 1024

6. CONCLUSION

We have proposed a novel scheme of 2-D optical code label for capacity enhancement of core GMPLS networks. In addition, the complexity of the core GMPLS switch using 2-D code label is reduced in comparison to the one using 1-D code label. Moreover, by using optical hard-limiters, the throughput of core GMPLS switch is improved significantly. The numerical result reveals that, when the code length is 300 and the number of input flows is 2000, the core switch throughput of our proposed GMPLS networks is able to achieve the peak value of 2000, which is twice as large as that of GMPLS networks using 1-D code label.

REFERENCES

1. L. Andersson, S. Bryant - The IETF Multiprotocol Label Switching Standard: The MPLS Transport Profile Case, *IEEE Internet Computing* **12** (4) (2008) 69-73.
2. A. Banerjee, J. Drake, J. P. Lang, and B. Turner - Generalized Multiprotocol Label Switching: An Overview of Routing and Management Enhancements, *IEEE Commun. Mag.* **39** (1) (2001) 144-150.
3. D. Awduche and Y. Rekhter - Multiprotocol Lambda Switching: Combining MPLS Traffic Engineering Control with Optical Crossconnects, *IEEE Commun. Mag.* **39** (3) (2001) 111-116.
4. E. Mannie et al - Generalized Multi-Protocol Label Switching (GMPLS) Architecture, IETF draft-ietf-ccamp-gmpls-architecture-05, Mar 2003, work in progress.
5. T. Khattab and H. Alnuweiri - Optical GMPLS Networks with Code Switch Capable Layer for Sub-Wavelength Switching, *Proc. of IEEE GLOBECOM 2004*, Nov. 2004.
6. T. Khattab and H. Alnuweiri - Optical CDMA for All-Optical Sub-Wavelength Switching in Core GMPLS Networks, *IEEE Selected Areas in Commun.* **25** (5) (2001) 905-921.

7. L. Tancevski, I. Andonovic - Wavelength hopping/time spreading code division multiple access systems, *Electron. Lett.* **30** (17) (1994) 1388-1390.
8. A. K. Basu, *Measure theory and probability*, Prentice-Hall of India, 1999.
9. L. Tancevski and L. A. Rusch - Impact of the beat noise on the performance of 2-D optical CDMA systems, *IEEE Commun. Lett.* **4** (8) (2000) 264-266.
10. D. Raychaudhuri - Performance Analysis of Random Access Packet-Switched Code Division Multiple Access Systems, *IEEE Trans. Commun.* **29** (6) (1981) 895-901.
11. Ngoc T. Dang, Anh T. Pham, and Zixue Cheng - Beat Noise Cancellation in 2-D OCDMA Systems using Optical Hard-limiter Array, *IEICE Trans. on Communications*, **E93-B** (2) (2010) 289-292.

TÓM TẮT

CẢI THIỆN HIỆU NĂNG MẠNG GMPLS LỖI SỬ DỤNG NHÃN MÃ 2-D VÀ BỘ GIỚI HẠN CÔNG SUẤT QUANG

Mạng lõi GMPLS bao gồm hai lớp: lớp chuyển mạch sợi quang (FSC) và lớp chuyển mạch bước sóng (LSC). Để mở rộng dung lượng chuyển mạch, lớp chuyển mạch mã (CSC) đã được đề xuất bổ sung. Tuy nhiên, việc thêm lớp chuyển mạch mã sẽ khiến cho mạng trở nên phức tạp hơn. Trong bài báo này, chúng tôi đề xuất một cơ chế chuyển mạch mã mới sử dụng nhãn mã 2-D. Trong cơ chế này, lớp LSC và lớp CSC được kết hợp làm một và gọi là lớp 2-D CSC. Nhờ đó, sự phức tạp của mạng lõi GMPLS sẽ được giảm đi trong khi dung lượng chuyển mạch vẫn được cải thiện. Ngoài ra, để giảm ảnh hưởng của nhiễu đa truy nhập (MAI) do việc sử dụng mã gây ra, chúng tôi đề xuất sử dụng các bộ giới hạn công suất quang tại các bộ chuyển mạch lõi. Kết quả phân tích cho thấy rằng, thông lượng của chuyển mạch tăng mạnh và có thể đạt được giá trị thông lượng đỉnh.