

Development of Tank Model to Predict the Flow to Thac Xang Reservoir, Vietnam

Phát triển mô hình bể chứa để dự báo lưu lượng dòng chảy đến hồ thủy điện Thác Xăng, Việt Nam

Ha Van Thuy^{1,*}, Nguyen Duc Khoat¹, Khong Cao Phong¹

¹Department of Mechanical and Electrical Engineering, Hanoi University of Mining and Geology, Vietnam

*Ha Van Thuy E-mail: hathuy5p1@gmail.com

Abstract

Efficient operation of a water source is pivotal in harnessing water resources and mitigating flood-related damages. Precise forecasting of inflow rates to dam reservoirs is crucial for effective reservoir control. As a result, extensive research at both international and domestic levels has been conducted to develop and optimize flow forecasting models. This article presents a demonstration of runoff forecasting with rainfall data using an established tank model. The model is implemented and visualized using MATLAB Simulink. To optimize and validate the model, data from studies of the Thac Xang hydropower reservoir are utilized. The proposed flow prediction model has been adjusted to achieve a correlation coefficient of 74.0%. This model was used to predict the flow rate for the period from 1971 to 1976, achieving a correlation coefficient of 70.0%. The model predicted a flow rate trend that closely matched the measured flow rate trend at the monitoring stations in this area. Although the correlation coefficient is not high in this case, the model can still be applied to predict flow and effectively manage and regulate the water resources at the Thac Xang hydroelectric reservoir in Vietnam.

Keywords: Development, Tank model; Thac Xang reservoir; MATLAB Simulink; Hydroelectric reservoir

Tóm tắt

Vận hành hiệu quả nguồn nước có vai trò then chốt trong việc khai thác tài nguyên nước và giảm thiểu thiệt hại do lũ lụt. Dự báo chính xác dòng chảy vào các hồ chứa là rất quan trọng để kiểm soát hồ chứa hiệu quả. Do đó, nghiên cứu sâu rộng ở cả cấp độ quốc tế và trong nước đã được tiến hành để phát triển và tối ưu hóa các mô hình dự báo dòng chảy. Bài viết này trình bày minh họa dự báo dòng chảy với dữ liệu lượng mưa sử dụng mô hình bể đã được thiết lập. Mô hình được triển khai và hiển thị bằng MATLAB Simulink. Để tối ưu hóa và kiểm chứng mô hình, dữ liệu nghiên cứu từ hồ thủy điện Thác Xăng được sử dụng. Mô hình dự báo dòng chảy đề xuất đã được điều chỉnh để đạt được hệ số tương quan là 74,0%. Mô hình này được sử dụng để dự đoán dòng chảy trong giai đoạn từ 1971 đến 1976 với hệ số tương quan là 70,0%. Mô hình này dự đoán xu hướng lưu lượng khá gần với xu hướng lưu lượng đo được tại các trạm quan trắc trong khu vực này. Mặc dù trong trường hợp này hệ số tương quan không cao nhưng mô hình có thể ứng dụng để dự báo dòng chảy nhằm quản lý, điều tiết hiệu quả tài nguyên nước tại hồ thủy điện Thác Xăng, Việt Nam.

1. Introduction

Accurate prediction of water inflow into hydropower reservoirs and irrigation dams is important. This information provides operators with essential data to formulate effective strategies for the utilization of water resources. Extensive scientific research has been conducted by researchers worldwide to develop forecasting models to predict reservoir inflow.

To predict the water flow, it is essential to employ Numerical Weather Prediction (NWP) models for weather forecasting

and Quantitative Precipitation Forecasting (QPF) models to estimate precipitation amounts. J. Zhang et al. presented a simplified algorithm for predicting the inflow volume into reservoirs one to six days in advance, based on QPF rainfall and the multilayer perceptron artificial neural networks (MPL-ANNs) forecasting model [1]. This algorithm has been integrated into practical software to support decision-making to predict daily flows for a range of over 20 reservoirs operated by the Fujian Power Grid Company in China.

A decision support system has been developed and presented in [2], which utilizes water flow forecasting to support decision-making during the flood phase of reservoir operation. The system incorporates the concurrent execution of models and scenario-based simulations of dam operation. Experimental evaluation of the system was conducted on La Conception Lake, which is located on the Mediterranean coast of Spain.

In addition, the system also serves the function of supporting decision-making for managing the supply of clean water from the reservoir through early flow forecasting. Donghee Lee et al. have developed a model for predicting the headwater flow of the reservoir [3]. In [4], Bin Luo et al. utilized a hybrid model based on deep learning techniques, which is a combination of Deep Belief Network (DBN) and Long Short-Term Memory (LSTM) for flow prediction.

Numerous studies conducted domestically have implemented diverse research approaches towards flow prediction models. In their studies, authors Ngo Le An and Nguyen Thi Bich Ngoc employed the Hydrologic Modelling System model (HEC-HMS) and Reservoir Operation Simulation Model

(HEC-RESSIM) in conjunction with the BOLAM meteorological model to forecast flood flows to major reservoirs within the Ba River basin [5]. In conjunction with data from the Ba River, author Luong Huu Dung et al. utilized the MIKE-NAM model to establish relationships between meteorological factors, hydrological factors, and water resource forecasting characteristics [6]. By utilizing the NOAA rainfall model as input for the URSB model, the authors conducted computations and simulations to forecast the flow on the Mekong River at stations between Luang Prabang and Mukdahan [7]. The accuracy and reliability of flow prediction models for reservoir operation and management are essential for effective reservoir operation and management. Author Trung Duc Tran et al. conducted research with the aim of enhancing the accuracy of flow predictions for reservoirs [8].

Through the examination of various literature, it is evident that flow prediction models have garnered significant attention from scientists across different countries, with extensive research and development efforts. Selecting an appropriate model for research, development, and application in specific national or river basin conditions is crucial due to the diverse and abundant parameters that impact the accuracy of these models.

The tank model, developed by Sugawara from the 1960s to the 1990s, has been continuously studied and developed by numerous author groups worldwide [9]. In Sugawara's

reports, he uses programming programs to calculate runoff simulations for basins and optimize model parameters [10]–[14]. In this article, the authors use MATLAB Simulink combined with Script to simulate and optimize model parameters. This solution allows users to easily change the structure of the basin model using Simulink's pick-and-drop interface. The model was initially tested with the Thac Xang hydroelectric reservoir basin in Lang Son.

2. Development of tank model

Since its first introduction by Sugawara and Fuyuki [15], several variants of the tank model have been proposed. Among them, the most famous variant is the model with four stacked tanks to capture the characteristics of rainfall-runoff in a catchment. It comprises a set of linear tanks connected in series, with outlet gates located at the sides and bottom of each tank as described in Figure 1.

The water discharge through the side gates forms surface flow, while the discharge through the bottom gates represents subsurface flow, with interflow between tanks indicating saturation and groundwater permeability [5].

Determining the coefficients for the model enables the calculation of the ratio between total input rainfall and the corresponding output flow, thereby facilitating the determination of the outflow hydrograph for the basin.

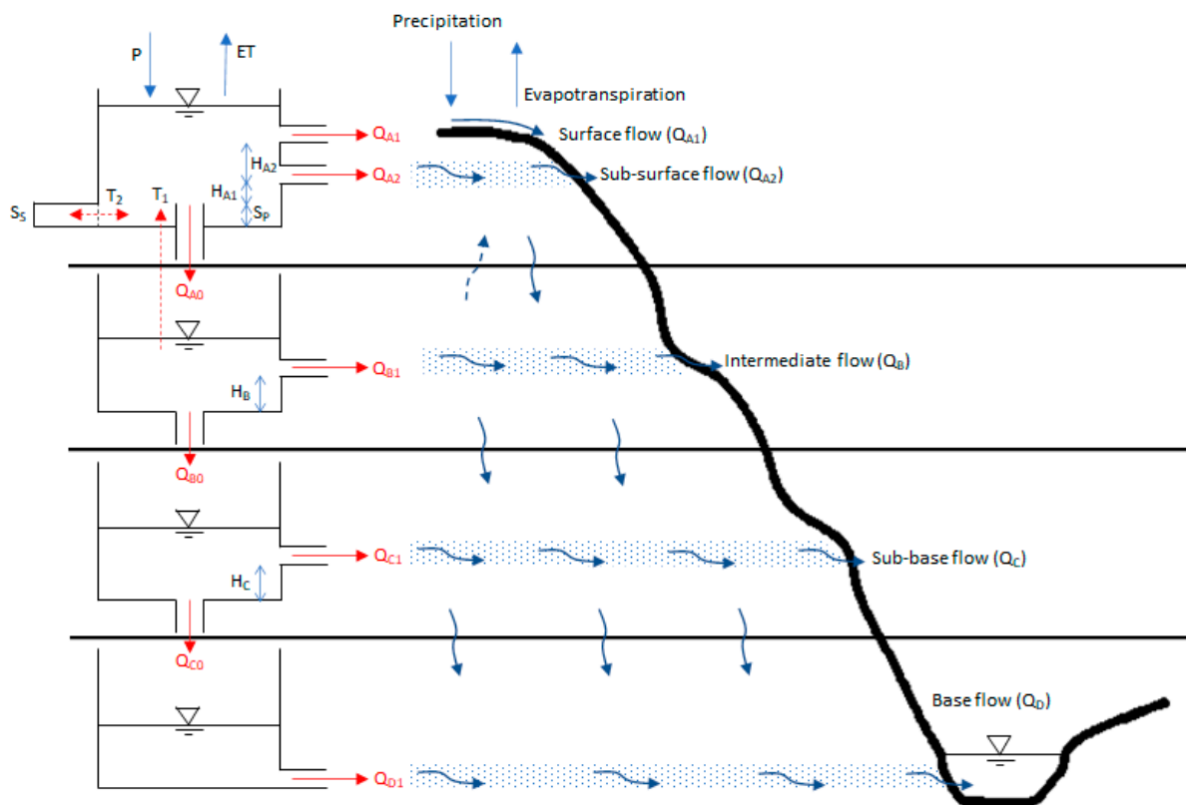

Figure 1: Modelling the characteristics of rainfall-runoff flow [9]

2.1. Operating principle of tank models

The operating principle of the tank model is relatively straightforward. The tank models include two types (Figure 2a and Figure 2b) that can be equivalently replaced by a linear

model as shown in Figure 2c by shifting the output of the tank model downward.

The linear reservoir model is considered a first-order inertial process given by $\beta/[\Delta + (\alpha + \beta)]$, where Δ represents the deviation, $1/(\alpha + \beta)$ is the time constant, and the ratio of output

to input is $\beta/(\alpha + \beta)$. The basic principle of adjusting the model parameters is as follows:

- (1) To modify the shape of the flow hydrograph, it is necessary to adjust $(\alpha + \beta)$. For example, to create a flow hydrograph with a higher jump, $(\alpha + \beta)$ needs to be increased, while a lower jump can be achieved by decreasing $(\alpha + \beta)$.
- (2) To modify the total output flow, it is necessary to adjust the parameter $\beta/(\alpha + \beta)$. For example, to increase the output flow without altering the shape of the flow hydrograph, the value of β should be increased while α is decreased, to keep the sum of α and β unchanged and vice versa.

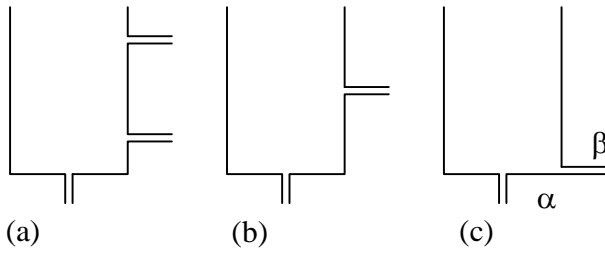

Figure 2: Tank model type: (a), (b), 02 Tank models; (c) Linear model for (a) and (b)

2.2. Dividing the reservoir into subsequent tanks

Based on the operating principle of the model, the parameters for each tank can be adjusted in the following ways:

- (1) Evaluation based on the shape and volume of the flow hydrograph during the high flow stage, which is the result of heavy rainfall, allows us to adjust the parameters of the uppermost tank.
- (2) Evaluation based on the flow hydrograph during the recession stage, the intermediate stage following the peak flow stage, enables us to adjust the parameters of the second tank.
- (3) Evaluation based on the base flow of the flow hydrograph allows us to adjust the parameters of the third and fourth tanks.

The challenge is how to divide the entire stages of the flow hydrograph into corresponding stages for each tank.

2.3. Utilizing an initialization model

The initialization model, as depicted in Figure 3, serves as the foundation for automating the process of adjusting the parameters of the reservoir.

The model takes into account rainfall and evaporation. Analyzed from the components of the computed flow hydrograph, the smaller stages 1, 2, 3, 4, and 5 correspond to the upper drain gates and lower drain gates of the upper reservoir, second reservoir, third reservoir, and fourth reservoir, respectively.

The division rule is expressed as follows:

Stage 1: The time window when the upper outlet of the uppermost reservoir plays a significant role in the overall outflow is dependent on stage 1. Specifically, when the ratio of the upper outlet's outflow to the total outflow of the reservoir model exceeds a constant value C, this content and time window is dependent on stage 1. Specifically:

$$y_1 \geq C(y_1 + y_2 + y_3 + y_4 + y_5) = C_y \quad (1)$$

where y_i represents the outflow of the i^{th} outlet as shown in Figure 4.

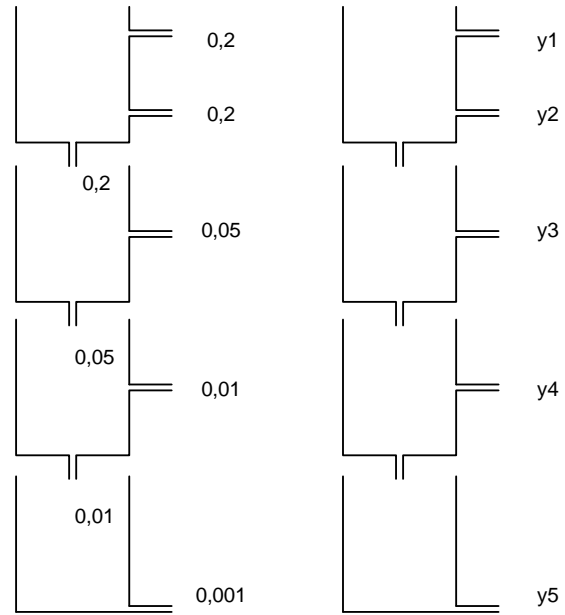

Figure 3: Initialization model

Figure 4: Output of the four tanks

Stage 2: When

$$y_1 < C_y < y_1 + y_2 \quad (2)$$

Stage 3: When

$$y_1 + y_2 < C_y < y_1 + y_2 + y_3 \quad (3)$$

Stage 4: When

$$y_1 + y_2 + y_3 < C_y < y_1 + y_2 + y_3 + y_4 \quad (4)$$

Stage 5: For the remaining cases

Values of 0, 50, 25, 10 and 5% are used for constant C, with 10% appearing to be a suitable option.

2.4. RQ(I) and RD(I) standards

In each stage $I = 1, 2, 3, 4,$ and 5 of the discharge flow, the calculated and observed logarithmic reduction ratio of computed and observed discharges is compared according to the following criteria:

$$RQ(I) = \frac{\sum_N \tilde{Q}(N)}{\sum_N Q(N)} \quad (5)$$

$$RD(I) = \frac{\sum_N [\log Q(N-1) - \log Q(N)]}{\sum_N [\log Q(N-1) - \log Q(N)]} \quad (6)$$

where Q is the observed discharge, \tilde{Q} is the computed discharge, I is the stage index, N is the number of days, Σ is the average total number of days within stage I, and Σ' is the sum of N days within the group of stage I, where $Q(N-1) - Q(N)$ is positive.

2.5. Response equation

Based on the fundamental principle stated above, the adjustment of parameters as shown in Figure 5 can be determined based on the RQ(I) and RD(I) standards.

When $RQ(I) > 1$ ($RQ(I) < 1$), it is necessary to decrease (increase) the control parameter of the side outlet and increase

(decrease) the parameters of the bottom outlet. This adjustment is accomplished by dividing the side outlet parameter equally and multiplying it with the bottom outlet parameter. When $RD(I) > 1$ ($RD(I) < 1$), it is necessary to decrease (increase) both parameters equally. This adjustment is achieved by dividing the parameters by $RD(I)$. The response provided by $RQ(I)$ and $RD(I)$ corresponds to the response changes and response rates in the corresponding automatic control system. Therefore, the feedback information for $RQ(1)$ and $RD(1)$ can be expressed as follows, where $AM0$, $AM1$, and $AM2$ are adjustment parameters:

$$(AM1 + AM2) = \frac{(A1 + A2)}{\sqrt{RQ(1)RD(1)}} \quad (7)$$

$$AM0 = \frac{A0\sqrt{RQ(1)}}{RD(1)} \quad (8)$$

Similarly, the response value $RQ(2)$ and $RD(2)$ are defined as follows:

$$AM1 = \frac{A1}{\sqrt{RQ(2)RD(2)}} \quad (9)$$

$$AM0 = \frac{A0\sqrt{RQ(2)}}{RD(2)} \quad (10)$$

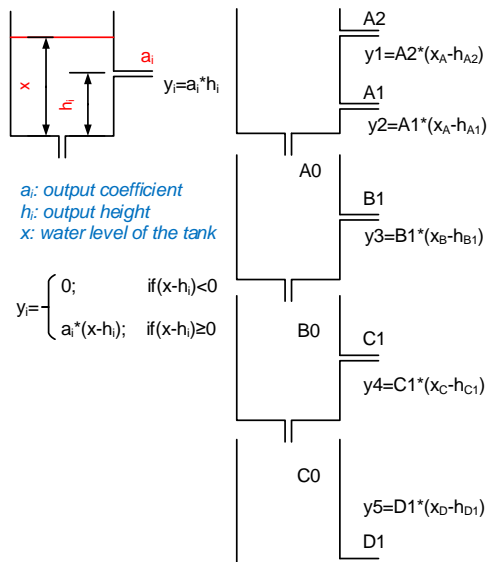

Figure 5: Input and output parameters of the model

By combining these formulas with the previous adjustments and using the mean of the two equations for $AM0$, we obtain the expressions:

$$A0 = \frac{A0}{2} \left[\sqrt{RQ(1)/RD(1)} + \sqrt{RQ(2)/RD(2)} \right] \quad (11)$$

$$AM1 = A1 / \left[\sqrt{RQ(2)RD(2)} \right] \quad (12)$$

$$A2 = (A1 + A2) / \left[\sqrt{RQ(1)RD(1)} \right] - AM1 \quad (13)$$

$$A1 = AM1 \quad (14)$$

Although adjusting the parameters of the uppermost tank will have impacts on the lower tanks, we ignore these impacts and adjust the parameters of the second tank using the $RQ(3)$ and $RD(3)$ standards:

$$B0 = B0\sqrt{RQ(3)}/RD(3) \quad (15)$$

$$B1 = B1 / \left[\sqrt{RQ(3)RD(3)} \right] \quad (16)$$

Similarly, we adjust the parameters of the third tank with $RQ(4)$ and $RD(4)$:

$$C0 = C0\sqrt{RQ(4)}/RD(4) \quad (17)$$

$$C1 = C1 / \left[\sqrt{RQ(4)RD(4)} \right] \quad (18)$$

Similarly, we adjust the parameters of the third tank with $RQ(4)$ and $RD(4)$: The tank model in Figure 6 does not have a bottom outlet in the fourth tank because at this level, we only consider cases where there is no seepage. In this scenario, the response of $RD(5)$ is determined by:

$$D1 = D1/RD(5) \quad (19)$$

However, the calculation of $RQ(5)$ feedback cannot be performed as mentioned above. We need to control the water supply from the upper tanks. If $RQ(5) > 1$ ($RQ(5) < 1$), we have to decrease (increase) the parameters of the bottom outlet of the upper tanks. The control of water supply to the fourth tank is accomplished by adjusting $C0$ of the third tank, and the change in the third reservoir is due to the variation in $C0$ is compensated by adjusting $B0$ etc. In this condition, we have the following expressions:

$$C0 = C0/RQ(5) \quad (20)$$

$$B0 = B0 / \sqrt{RQ(5)} \quad (21)$$

$$A0 = A0 / \sqrt[4]{RQ(5)} \quad (22)$$

In some cases, the values of $RQ(I)$ and $RD(I)$ can have significantly different values from 1. To ensure that the response values do not exceed certain limits, we restrict them within the range of (1/2 to 2). For example, if the values of $RQ(I)$ and $RD(I)$ are greater than 2, they will be replaced by 2, and if they are smaller than 1/2, they will be replaced by 1/2.

3. Constructing MATLAB Simulink model

3.1. Constructing the tank model using MATLAB

Assume the water level in each tank is denoted as x , the water level at the i^{th} outlet of the tank (including the bottom outlet) is h_i , and the discharge coefficient (permeability) at each outlet is a_i . The water discharge at the i^{th} outlet is determined by the equation (23).

$$y_i = \begin{cases} 0; & \text{if } (x - h_i) \leq 0 \\ a_i \times (x - h_i); & \text{if } (x - h_i) > 0 \end{cases} \quad (23)$$

The accumulated water in the reservoir is equal to the cumulative inflow of water minus the cumulative outflow (permeability) from the reservoir.

With the analysis mentioned above, the simulation structure of the reservoir is modelled as shown in Figure 6. In which, a_{ij} , h_{ij} are the output coefficients and outlet heights of the i^{th} tank and j^{th} outlet; B is the coefficient of bottom output. In the case of a reservoir with only one outlet or a bottom outlet (without seepage into the lower reservoir), the discharge coefficient (permeability) a_i is set to 0.

In the case of evaporation, the accumulated water in the reservoir is reduced by the amount of evaporation. Evaporation in the lower reservoirs only occurs when the water level in the upper reservoir is at 0.

The simulation structure for the entire watershed is determined using the 04-reservoir model depicted in Figure 7.

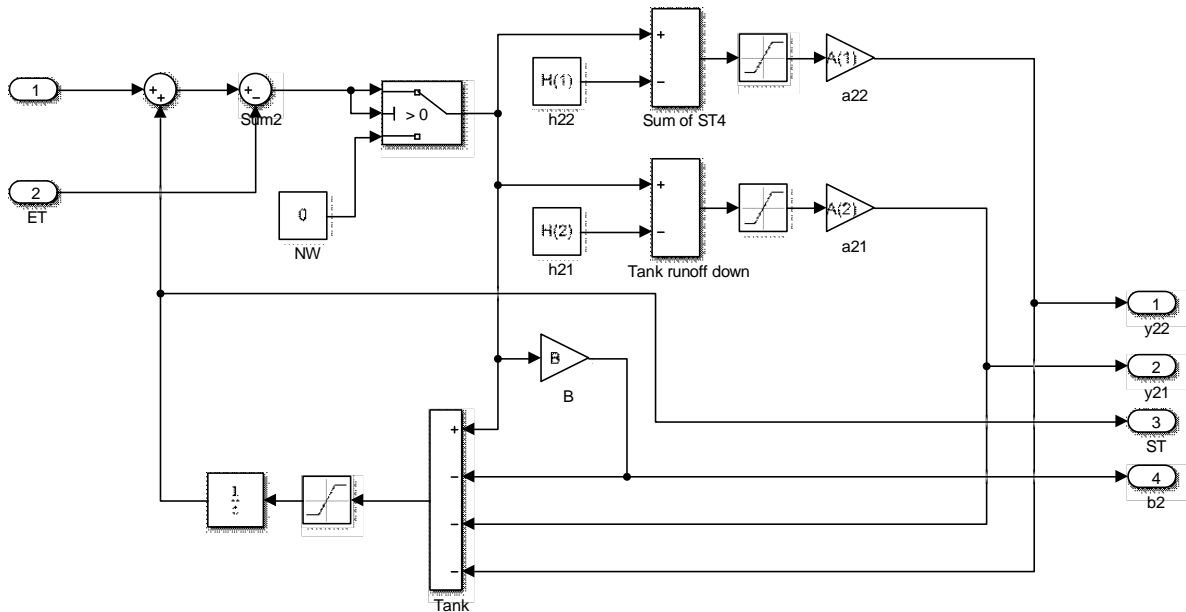

Figure 6: A single tank model (a_{ij}, h_{ij}, y_{ij} : i^{th} tank; j^{th} output)

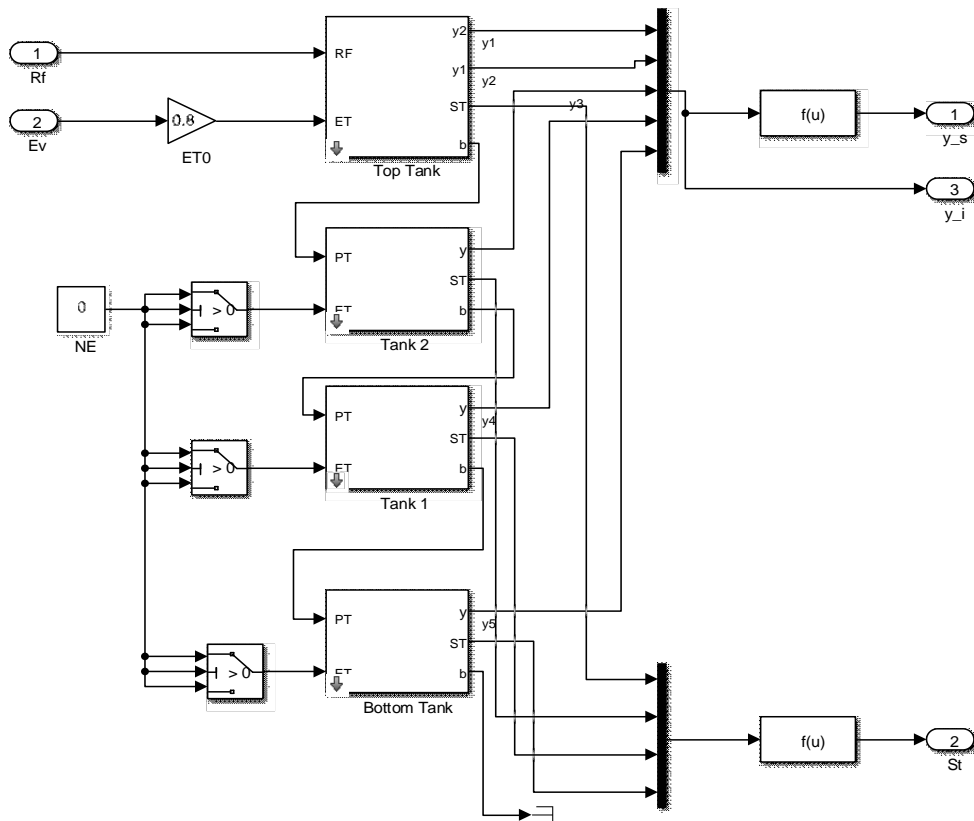

Figure 7: Four tanks model for Thac Xang basin

3.2. Input data

The data used in the MATLAB Simulink model for simulation purposes are rainfall and flow data provided for the Thac Xang Hydroelectric Reservoir in Hung Viet commune, Trang Dinh district, Lang Son province, Vietnam. These data include rainfall data collected from 05 rainfall measurement sta-

tions (Figure 8) in the watershed areas of the Thac Xang reservoir (Vietnam), as well as flow rate measurements at the Van Mich station before flowing into the reservoir. The rainfall data collected will be input into the reservoir model to calculate the flow into the Thac Xang reservoir. The calculated results will be analyzed and compared with the measured flow values at the Van Mich station to adjust the model parameters.

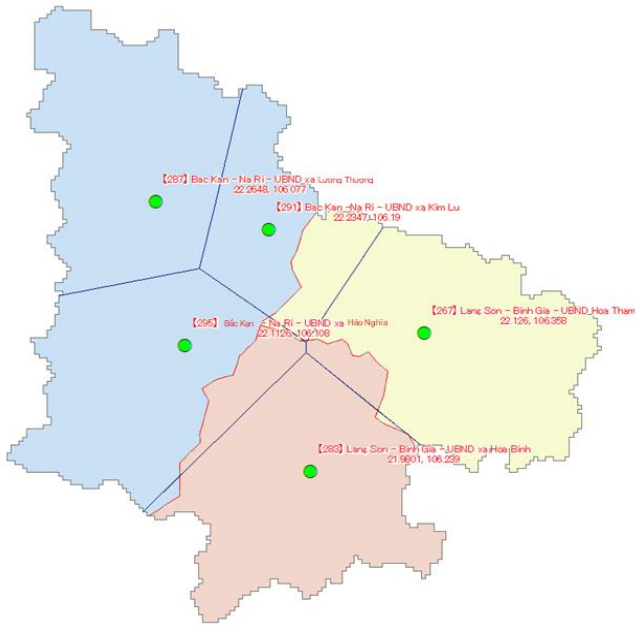

Figure 8: Rainfall measurement stations in the Thac Xang Reservoir basin

3.3. Model adjustment

The simulation data will be put into the MATLAB Simulink model which will run and generate the computed flow rate result, denoted as \hat{Q} . This calculated flow rate will be compared

with the measured flow rate Q collected at the Van Mich station to adjust the parameters of the reservoir model.

The parameter adjustment process is performed following Equations (1)-(22) using a script written in an M-file. In this M-file, the script calls the MATLAB Simulink program to obtain the results, performs parameter adjustment for the next run, and iterates through the Run-Obtain Results-Parameter Adjustment cycle with a predetermined number of iterations to find the best parameter set.

4. Result and Discussion

4.1. Model adjustment result

In order to determine the adjustment parameters for the forecast model, the data from a 10-year period (from 1960 to 1970) was used to calibrate the model. Based on the obtained best parameter set, the parameters are then validated using data from a subsequent 5-year period (from 1971 to 1976).

The MATLAB script performs 100 iterations to run and adjust the parameters using the data from 1960 to 1970 to obtain the best result. The results of the parameter adjustment with the 10-year data are shown in Figure 9, with a correlation coefficient $R = 0.74$ between the computed flow rate (dark yellow) and the measured flow rate (light blue). Mean Square Error (MSE) is 3024.2; Root Mean Square Error (RMSE) is 54.9925

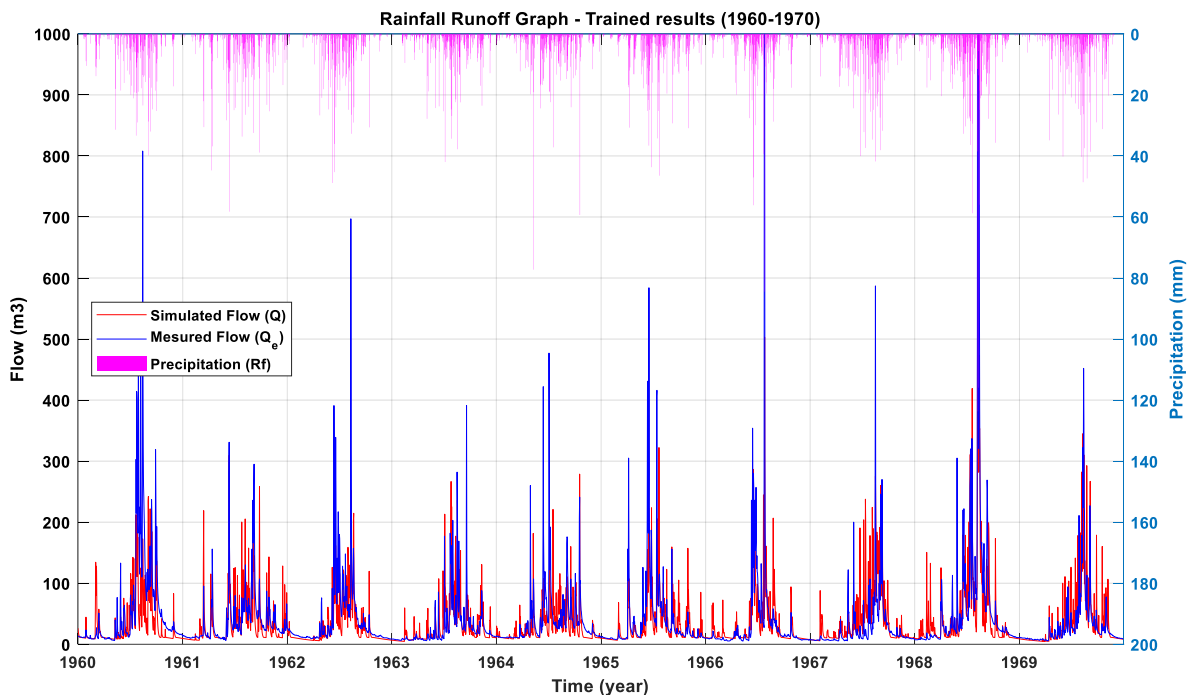

Figure 9: Graph of model calibration results: Best performing scenario

The results of the model adjustment process showed that the changing trends between the measured rainfall and the measured flow are quite close to each other. At times of high measured rainfall, such as mid-1966 and mid-1968, the flow also increased greatly. In addition, the change law of the predicted flow is also very close to the change law of the measured flow. About the annual maximum flow, the predicted results are

smaller than the measured results. This is one of the limitations that needs to be overcome of this prediction models.

4.2. Verification of the forecasted model

Using the parameter set obtained from the adjustment process, the model is then tested with the 5-year comparison data from 1971 to 1976. The validation results are presented in Figure 10, with a correlation coefficient $R = 0.70$. Mean Square Error

(MSE) is 4976.1; Root Mean Square Error (RMSE) is 70.5413. The comparison results in Fig. 10 show that the changing trends of predicted flow and measured flow in the period from 1971 to 1976 are quite close to each other. According to the obtained results, the flow is usually low at the beginning of each year then gradually increases and reaches the highest value after the middle of each year (from May to September). This is the time when it rains the most in the northern provinces of Vietnam.

Every year, the maximum values of predicted flow were smaller than the maximum value of measured one. In particular, a very large difference can be observed in the year 1972 (maximum predicted flow is 510 m³/day, while maximum measured flow is 1300 m³/day) and year 1974 (the maximum

predicted flow is 924 m³/day, while the maximum measured flow is 779 m³/day). These differences are caused by many different sources such as:

- The time to collect adjusted data is not enough long (only 10 years), so it did not cover all the changing cycles of hydrological characteristics in the study area.
 - The used data set was recorded manually since the 1960s, so the reliability of the data is not high.
 - Rainfall is unevenly distributed, the rain gauge grid is sparse (05 stations throughout the study area), etc.
- And these limitations will also be the next research directions of this study.

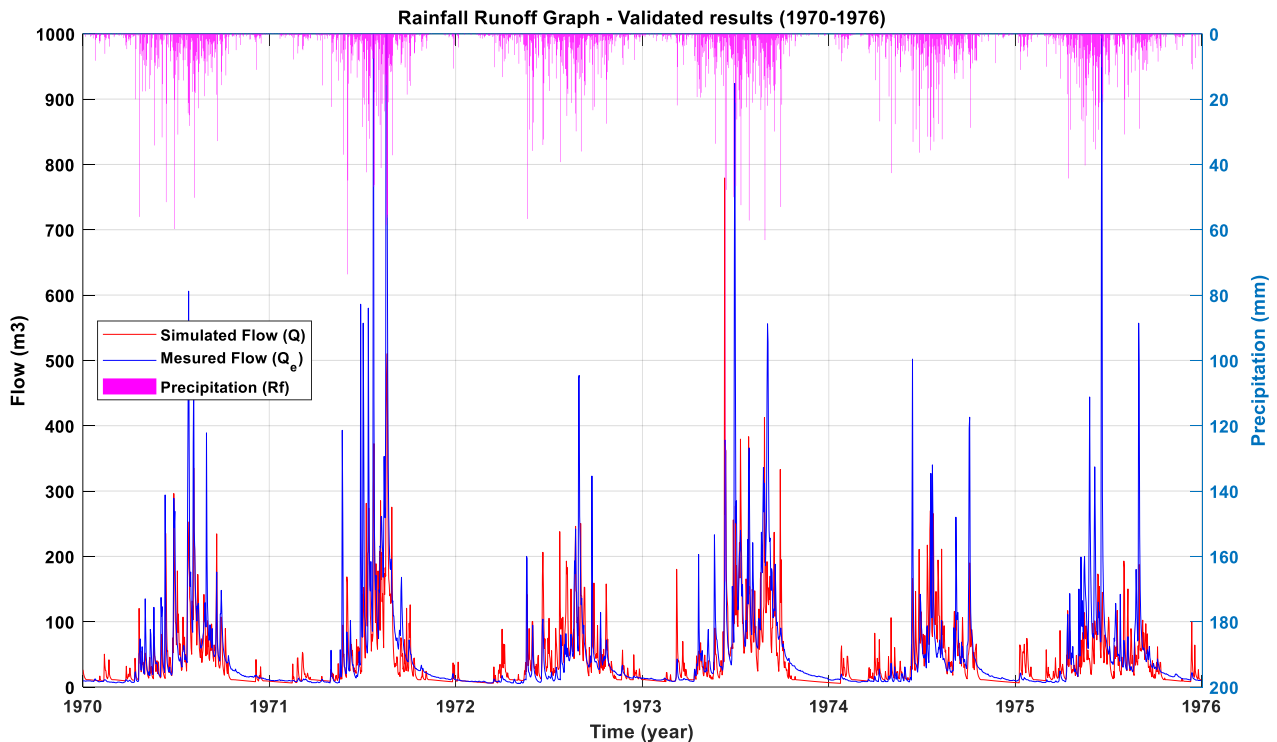

Figure 10: Graph of validations from 1971 to 1976.

The model's performance in predicting flow rates demonstrates its potential application in flow forecasting. Although the achieved results may not have a high correlation due to the absence of factors such as the hydrogeological characteristics of the area, seasonal variations, high and low water cycles, and expert adjustments, the model's ability to capture and predict flow patterns is evident. Further improvements can be made by incorporating these influential factors and incorporating expert adjustments into the model.

5. Conclusion

This study presented the application of the tank model in simulating rainfall-runoff for the Thac Xang hydroelectric reservoir, Vietnam. The conclusions of this study were drawn as following:

- The tank model has been successfully applied to simulate the relationship between rainfall and flow in the Thac Xang hydroelectric reservoir basin, Vietnam. Using

MATLAB Simulink allows researchers and users to easily change the model structure (number of tanks, number of outputs) to match the characteristics of the basin.

- Using the used data to adjust the model to be the rainfall and flow for 10 years from 1960 to 1970, in comparing with the measured flow results, the predicted results using tank model with the correlation of 74.0%.
- The proposed model was used to predict the flow rate in the period from 1971 to 1976 at Thac Xang hydroelectric reservoir, Vietnam with the correlation coefficient of 70.0%.
- The maximum value of predicted flow was smaller than the maximum value of measured one. In particular, a very large difference can be observed in the year 1972 and the year 1974.

These differences are caused by many different sources. These limitations will also be the next research directions of this study, such as:

- Use tank models with more than 2 side outlets, which can be suitable for complex terrain in the Thac Xang reservoir basin.
- Collect more data on rainfall and runoff to train the model.
- Renovating the rain gauge grid (15x15 km, 10x10 km, 5x5 km).
- Combine rain gauge data with remote sensing data to improve rain models.

Acknowledgement

The authors would like to express their sincere gratitude to Su Pan 1 Hydroelectric Joint Stock Company for providing the data used in this research study.

References

- [1] J. Zhang, C. Cheng, S. Liao, X. Wu, and J. Shen, "Daily reservoir inflow forecasting combining QPF into ANNs model," *Dly. Reserv. inflow Forecast. Comb. QPF into ANNs Model*, vol. 6, no. 1, pp. 121–150, 2009, doi: 10.5194/hessd-6-121-2009.
- [2] A. LINARES, J. REGODÓN, L. PANIZO, M.-D.-M. GALLARDO, and P. MERINO, "A DSS For Reservoirs Operation Based On The Execution Of Formal Models," 2014.
- [3] D. Lee, H. Kim, I. Jung, and J. Yoon, "Monthly reservoir inflow forecasting for dry period using teleconnection indices: A statistical ensemble approach," *Appl. Sci.*, vol. 10, no. 10, 2020, doi: 10.3390/app10103470.
- [4] B. Luo, Y. Fang, H. Wang, and D. Zang, "Reservoir inflow prediction using a hybrid model based on deep learning," *IOP Conf. Ser. Mater. Sci. Eng.*, vol. 715, no. 1, 2020, doi: 10.1088/1757-899X/715/1/012044.
- [5] N. L. An and T. Bích, "Nghiên cứu dự báo dòng chảy lũ đến hồ chứa trên lưu vực sông Ba," *Khoa học kỹ thuật Thủy lợi và Môi trường*, vol. 8, pp. 9–16, 2012.
- [6] L. H. Dũng, C. N. N. Sơn, T. Đ. Thiện, and D. H. Phương, "Ứng dụng mô hình MIKE-NAM dự báo các đặc trưng tài nguyên nước trong lưu vực sông Ba," *Tạp chí Khoa học biến đổi khí hậu*, no. 1, 2020.
- [7] Đ. Q. Trí and L. T. Huệ, "Mô hình hóa dự báo dòng chảy lưu vực sông Mê Công, Việt Nam," in *HNKH Khí tượng thủy văn và hải dương học*, 2016, no. October.
- [8] T. D. Tran, V. N. Tran, and J. Kim, "Improving the accuracy of dam inflow predictions using a long short-term memory network coupled with wavelet transform and predictor selection," *Mathematics*, vol. 9, no. 5, pp. 1–21, 2021, doi: 10.3390/math9050551.
- [9] J. W. Lee, S. D. Chegal, and S. O. Lee, "A review of tank model and its applicability to various korean catchment conditions," *Water (Switzerland)*, vol. 12, no. 12, 2020, doi: 10.3390/w12123588.
- [10] M. S. I. W. E. O. Y. Katsuyama, "Method of Automatic Calibration of tank Model (Third Report) - Automatic Calibration Program for Flood Analysis," 1980.
- [11] M. S. I. W. E. O. Y. Katsuyama., "Method of Automatic Calibration of Tank Model (Fourth Report) - Semiautomatic Procedures to calibrate the Parameters relating with the Positions of Side-outlets, the Soil Moisture Structure and the Intake of Irrigation Water." 1982.
- [12] M. Sugawara, "Tank Model - For the Derivation of River Discharge from Rainfall," 1985.
- [13] M. S. I. W. E. O. Y. Katsuyama, "Tank Model Programs for Personal Computer and the Way to Use," 1986.
- [14] M. S. E. Ozaki, "Method of Automatic Calibration of the Tank Model (Fifth Report): Automatic or Semi-Automatic Procedures to Calibrate the Multiplication Factor of the Precipitation in Snowy Basins," 1987.
- [15] M. Sugawara, M.; Fuyuki, "A Method of Revision of River Discharge by Means of a Rainfall Model," 1956.