

RESEARCH ON DESIGNING AND MANUFACTURING 3-AXIS MINI CNC MILLING MACHINE USED FOR TEACHING

Vuong Gia Hai¹, Nguyen Manh Hung²

¹Faculty of Technology and Engineering, ²Faculty of Information Technology

¹Email: haivg@dhhp.edu.vn

Received: 26/8/2024

Revised: 17/9/2024

Accepted: 18/10/2024

Abstract: Nowadays, in the Mechanical Engineering and Mechatronics Engineering programs at Hai Phong University, there is a crucial need for models and equipment to support learning, allowing students to gain practical knowledge through hands-on experience. However, practical devices such as automated production systems, CNC machining machines, and robots are often costly and difficult to acquire for educational programs. A mini CNC milling machine is essential for student learning and research. Mini CNC milling machines are small-scale devices used for engraving small objects like jewelry and souvenirs, etc. They are suitable models for teaching and learning purposes. In this article, the authors present their research results on designing, manufacturing, and testing a 3-axis mini CNC milling machine using Mach3 software. The machine performs well on various materials such as wood, acrylic, plastic, and printed circuit boards. It can be applied in production or used for training in CNC programming and operation.

Keywords: Manufacturing, CNC, milling machine, Mach3, automated machining, design.

NGHIÊN CỨU THIẾT KẾ VÀ CHẾ TẠO MÁY PHAY CNC MINI 3 TRỤC SỬ DỤNG CHO ĐÀO TẠO

Tóm tắt: Hiện nay, trong chương trình đào tạo ngành Kỹ thuật cơ khí và Kỹ thuật cơ điện tử của trường Đại học Hải Phòng việc cần có những mô hình, thiết bị hỗ trợ việc học tập giúp sinh viên có thêm những kiến thức thực tế thông qua việc thực hành là hết sức cần thiết. Tuy nhiên, các thiết bị như các hệ thống sản xuất tự động, các máy gia công CNC, robot thực tế thường có giá thành cao, khó trang bị được cho các chương trình đào tạo. Và máy phay CNC là một thiết bị hỗ trợ việc học tập và nghiên

cứu hết sức cần thiết cho sinh viên. Máy phay CNC mini là dòng máy CNC cỡ nhỏ, dùng khắc những vật kích thước nhỏ như đồ trang sức, đồ lưu niệm... là một dạng mô hình phù hợp cho việc giảng dạy và học tập. Trong bài báo này, nhóm tác giả trình bày một số kết quả của việc nghiên cứu thiết kế, chế tạo và chạy thử máy phay CNC mini 3 trục sử dụng chương trình Mach3. Kết quả máy hoạt động tốt trên rất nhiều vật liệu như gỗ, mica, nhựa, mạch in... Máy có thể ứng dụng trong sản xuất hay đào tạo lập trình, vận hành máy phay CNC.

Từ khóa: Chế tạo, CNC, máy phay, Mach3, tự động gia công, thiết kế.

1. INTRODUCTION

CNC (Computer Numerical Control) machines are a type of industrial machinery. They operate based on the principle of automated control with computer assistance, in which the components are automatically programmed to function in a sequence of events at predetermined speeds to produce a workpiece with the required shape and dimensions [1].

CNC machines have high cutting efficiency and significantly reduce

auxiliary time, thus increasing the level of automation [2]. Depending on the level of automation, CNC machines can simultaneously perform multiple movements, automatically change tools, correct errors, automatically check the dimensions of parts, and automatically adjust the relative positional deviations between the tool and the workpiece. The ability to change the type of manufactured product using CNC machines is quick because only the control program needs to be changed without altering the machine's structure or adding specialized fixtures [3].



Figure 1. Steel and wood products after being engraved by a CNC machine [4, 5]

Nowadays, CNC machines are gradually replacing traditional machining equipment and playing an indispensable role in production activities, available in a variety of types and sizes. CNC machines

are used in mechanical processing, wood carving, engraving patterns, and designs on gift products,.... The products created by CNC machines are highly aesthetic and of good quality.

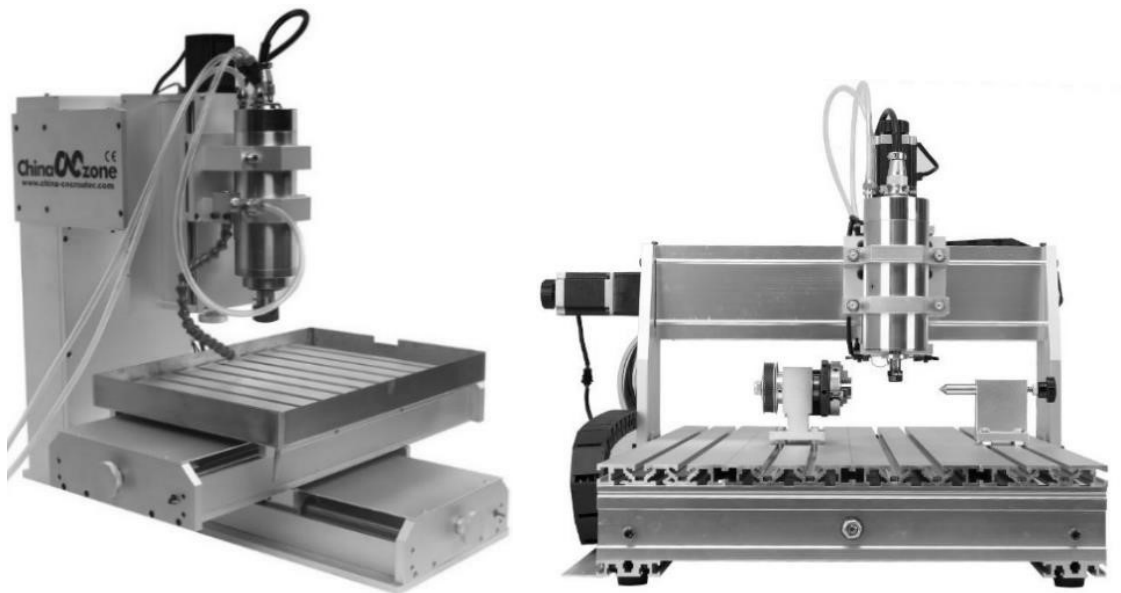

Figure 2. 3-axis mini CNC machine [6], 4-axis mini CNC machine [7].

2. STUDY OVERVIEW

Although CNC machines have increasingly affirmed their role and position in the cutting machining sector. However, in Vietnam the cost of importing CNC machines remains very high. Additionally, when these machines encounter issues, replacement and adjustments can be quite complex and expensive. For individual users or small production facilities, as well as educational institutions that teach CNC programming and operation, such as universities, colleges, and vocational schools, it is essential to optimize costs when investing

in machines. Therefore, researching and designing a low-cost, efficient 3-axis mini CNC milling machine is necessary. This approach helps optimize costs and provides greater autonomy in manufacturing and using the machine.

The study methodology employed by the team in the paper involves a combination of theoretical research and experimental work. The team studied several published works on the methods for calculating and designing mini CNC machining machines. Based on specific practical requirements, the group proceeded with the calculations, design, and construction of the machine

drawings. The author then conducted experimental fabrication of the machine according to the design and performed trial machining on some details to verify the reliability of the designed machine against the set requirements.

In this paper, the author presents the results of the research on the design and fabrication of a 3-axis mini CNC milling machine.

3. DESIGN OF THE STRUCTURE OF THE 3-AXIS MINI CNC MACHINE

3.1. Operating Principle of the Machine

The operating principle of a 3-axis CNC machine is illustrated in Figure 3. The 3-axis CNC milling machine comprises a high-speed spindle that is equipped with a cutting tool, such as a milling cutter, drill, or reamer, to cut the product. During operation, the spindle rotates and moves along the Z-axis. When machining profiles on a flat surface, the workpiece is fixed on the machine table and moves along the X and Y axes

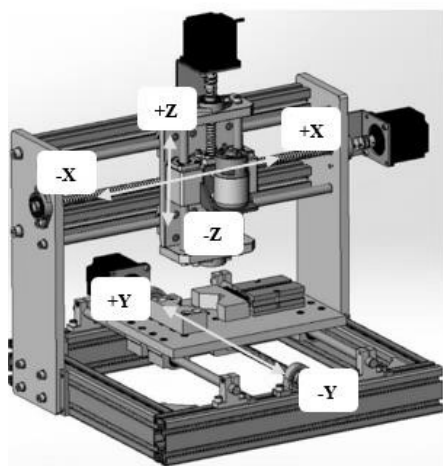

Figure 3. Schematic Diagram of the 3-Axis Mini CNC Milling Machine

3.2. Kinematic Design for the Machine

Based on research and comparison of various 3-axis CNC machine options, the author has identified the kinematic design approach as depicted in Figure 4.

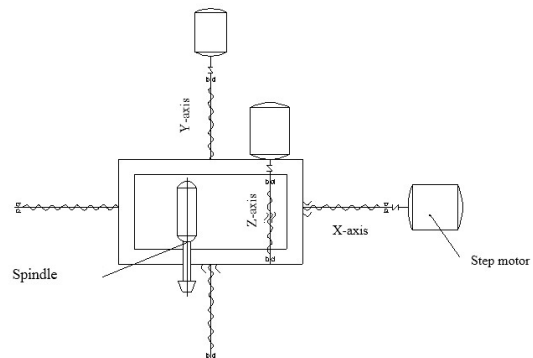

Figure 4. Kinematic diagram of 3-axis mini CNC milling machine

The design of the 3-axis mini CNC milling machine includes a product-holding table, a main spindle rotating at high speed with various cutting tools for machining operations. The vertical movement of the tool is controlled by the Z-axis assembly, while the X and Y-axis assemblies facilitate linear movements for shaping operations. When power is supplied to the motors attached to each axis and transmitted through the X-axis lead screw, it moves the Z-axis accordingly. The motor attached to the Y-axis, when activated, drives the table to a specific position. Activating the motor on the Z-axis assembly causes the spindle with the cutting tool to move up and down, thereby creating a specified cutting depth.

3.3. Design of the Z-axis Assembly

The structure of the Z-axis assembly, as shown in Figure 5, functions to translate the cutting tool along the Z-axis during

machining. The Z-axis travel distance is 110mm and includes two support plates, top and bottom, for mounting the guide rails and lead screw for the Z-axis.

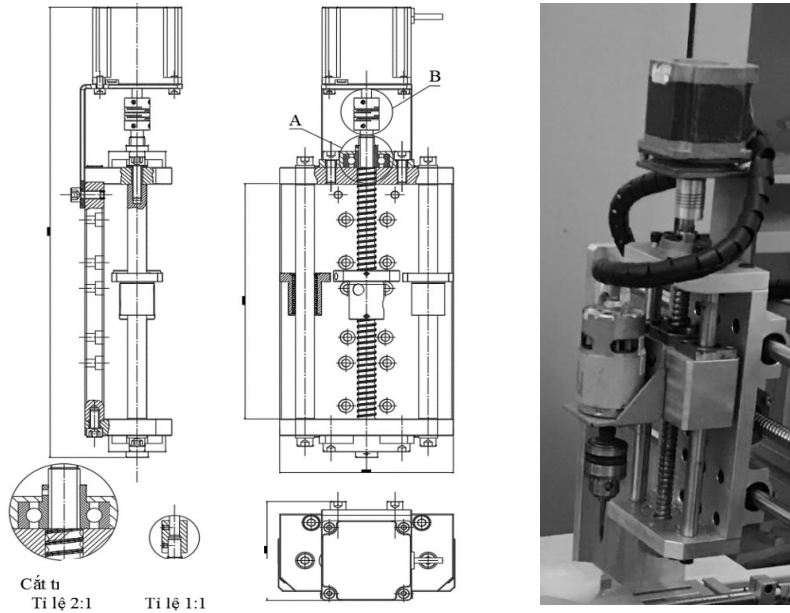

Figure 5. Structure of the Z-axis assembly

3.4. Design of the X-axis Assembly

The structure of the X-axis assembly, as shown in Figure 6, functions to control

the linear movement of the machine table along the X-axis. The X-axis travel distance is 285mm.

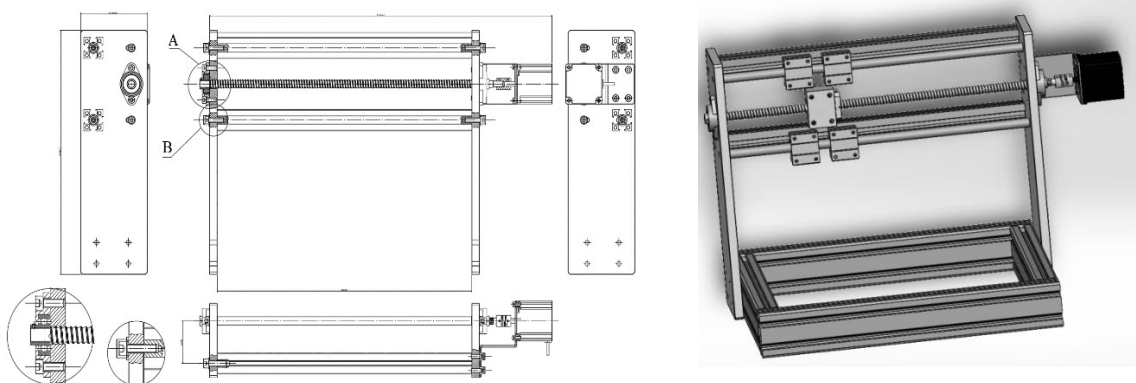

Figure 6. Structure of the X-axis assembly

3.5. Design of the Y-axis Assembly

The structure of the Y-axis assembly, as shown in Figure 7, functions to control

the linear movement of the machine table along the Y-axis. The Y-axis travel distance is 250mm.

4. CONTROL SYSTEM OF THE 3-AXIS MINI CNC MILLING MACHINE

4.1 Selection of Control Software for the Machine

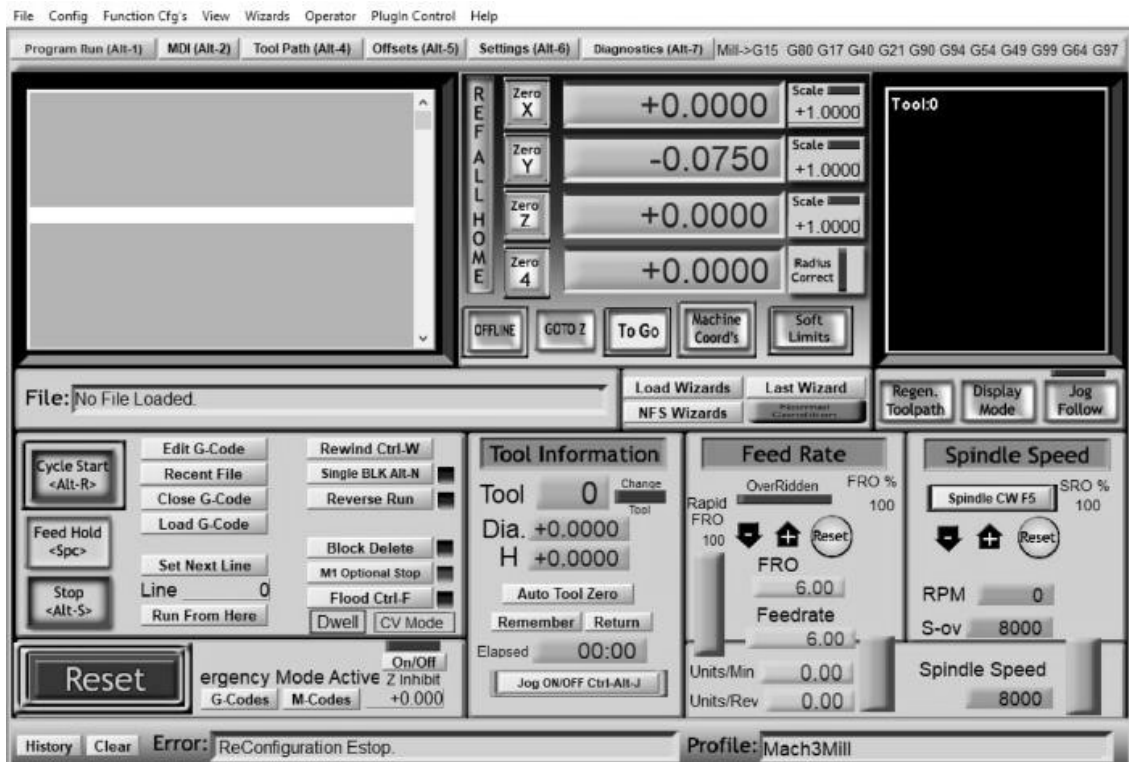

Figure 9. Interface screen when using Mach3 to control the machine

There are many software options available for controlling CNC milling machines in practice, such as Fanuc, NCstudio, and Mach3. The author team has chosen Mach3 as the control software for its diverse functionalities, attractive interface, ease of system parameter setup, and user-friendliness. Mach3 supports extended programming capabilities with VB Scripting, allows direct import of DXF, BMP, JPG, and HPGL files through LazyCam and Visual Gcode display, and supports direct import of DXF, BMP, and

JPG files through LazyCam software as per [8]. Its simulation capabilities provide clear visualization of the machining process, leading to significant cost savings during machine fabrication.

According to [8], the software operates in an open-loop format. Therefore, when applying Mach3 to control the 3-axis mini CNC milling machine, the authors had to design it in an open-loop configuration to facilitate the setup and operation of the machine effectively.

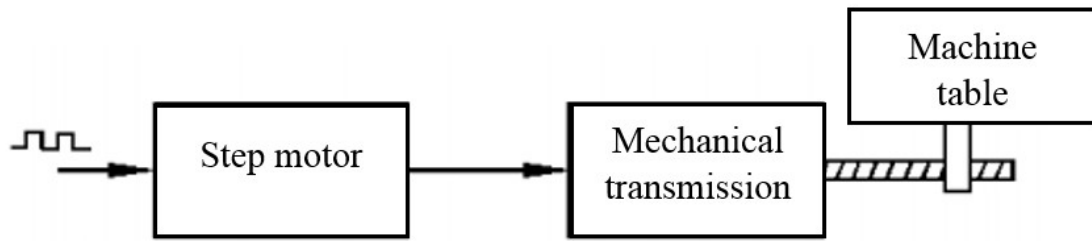

Figure 10. Open-loop control [8]

4.2. Control Structure Diagram of the Machine

The control structure diagram of the machine is depicted in Figure 11. In this diagram:

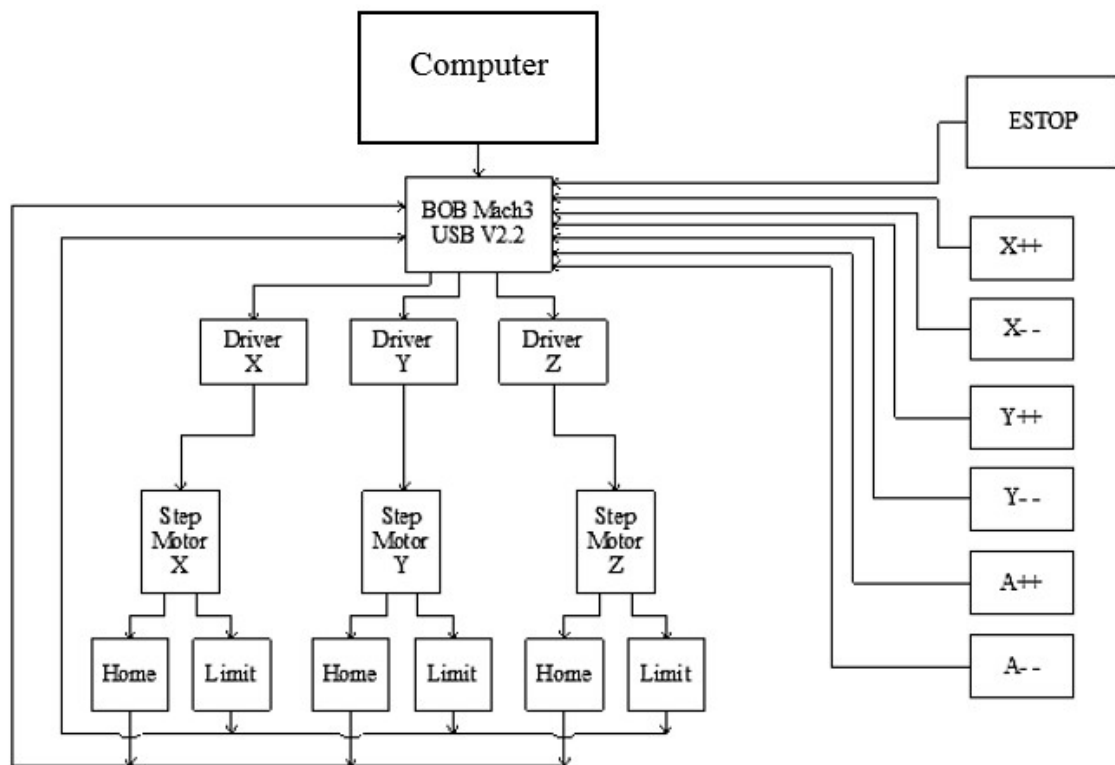

Figure 11. Control Structure Diagram of the Machine

- Mach3 Software and Computer: It functions as the CNC controller, managing the entire system. The CNC BOB MACH3 USB V2.0 board is used with Mach3 software on the computer via USB

interface with just a few simple setup steps.

- Stepper Motors and Stepper Motor Drivers: Drive the machine tables to translate the movements of the cutting head during machining.

- Limit Switches: Limit the travel range of the machine tables to prevent collisions with supports or other parts.

4.3. Control Circuit Diagram of the Machine.

The control circuit diagram of the machine as shown in Figure 12. The TB6600 stepper motor drivers are

connected in a common positive configuration to conserve USB resources, with the remaining negative pins connected to corresponding pins on the Mach3 BOB. The drivers operate using a 24V power supply. The limit switches for each axis are collectively connected and input to the respective pins on the Mach3 BOB: IN1, IN2, IN5.

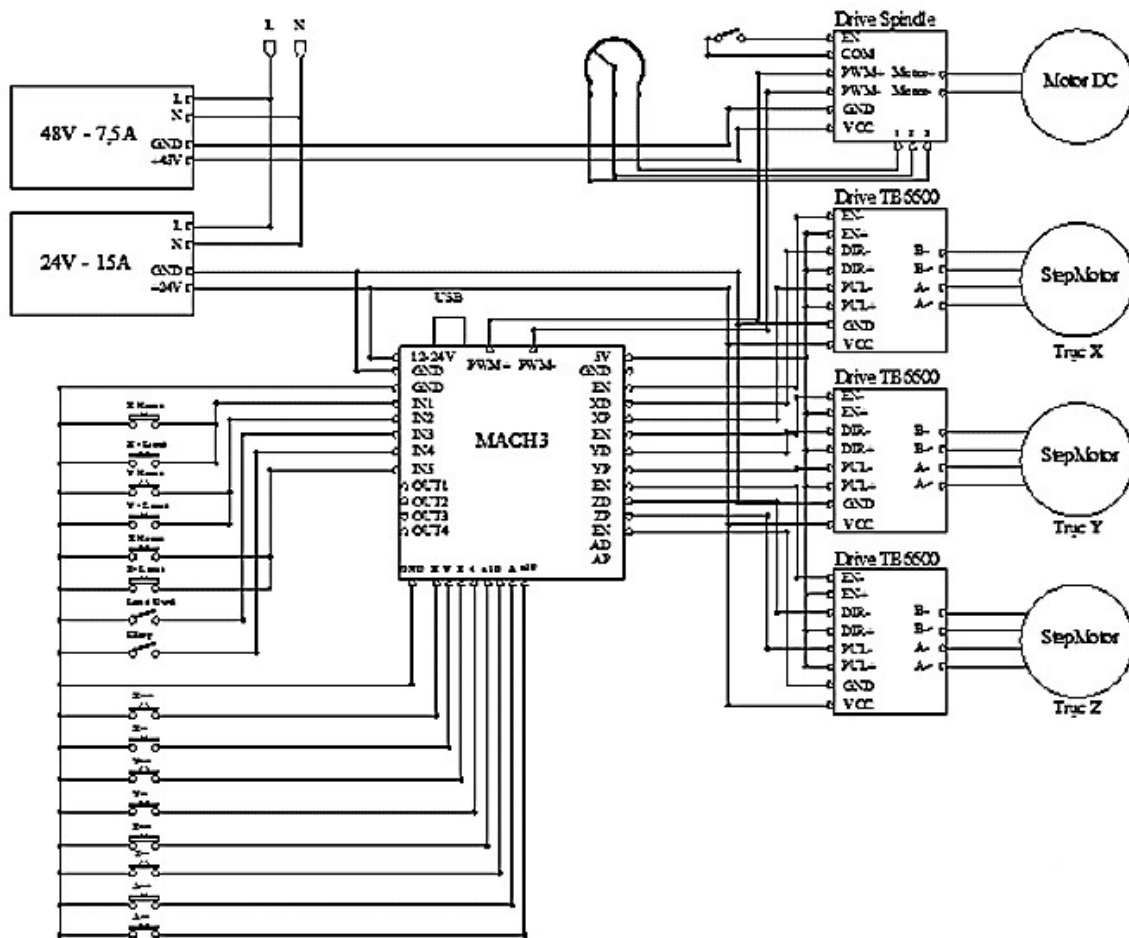

Figure 12. Control Structure Diagram of the Machine

5. MANUFACTURING AND TESTING OF THE MACHINE

The 3-axis mini CNC milling machine was manufactured, assembled, and tested at

the workshop of Hai Phong University. The results of the machine are shown in Figure 13. After a period of usage, the machine operated well, meeting the design

requirements. The technical specifications of the machine are presented in Table 3.1.

Following the completion of the manufacturing process, the research team conducted operational tests to assess the accuracy of the machine compared to its

design. They tested the operation of the 3-axis CNC milling machine and subsequently machined several components. The results of the operational process demonstrated the reliability of the designed and manufactured system (Table 3.2).

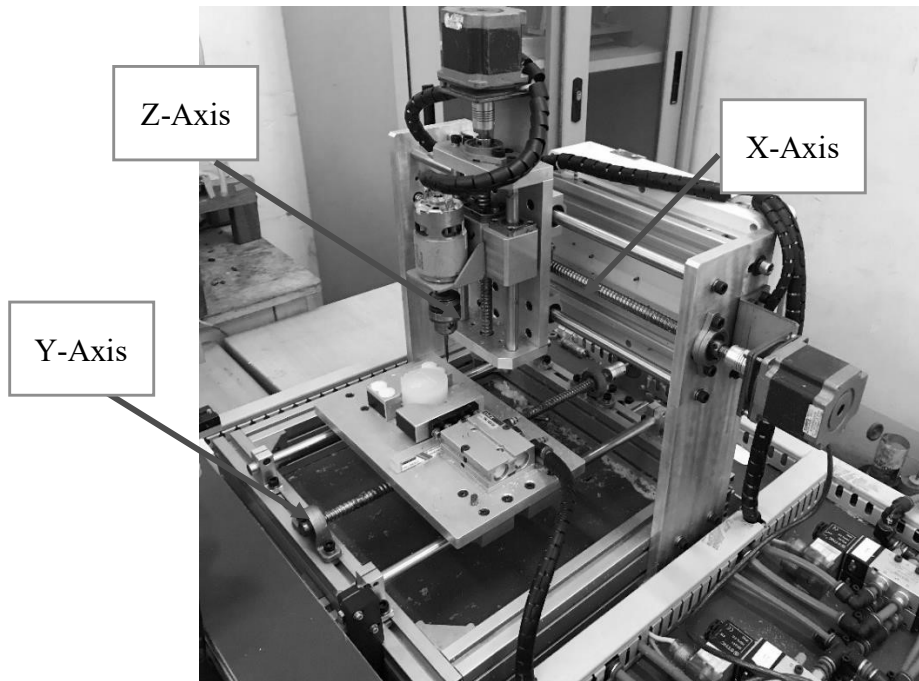

Figure 13. The workpiece is clamped onto the machine for machining.

Table 1. Machine specifications

<i>Technical specifications</i>	<i>Specifications</i>
CNC Milling Machine	
Machine dimensions	554 x 480 x 480 mm
Table dimensions	250 x 160 mm
Maximum workpiece dimensions during machining	250 x 150 x 50 mm
Spindle motor for milling and engraving	Power: 400W Air-cooled motor Operating voltage: 12VDC - 48VDC Maximum current intensity: 6A

<i>Technical specifications</i>	<i>Specifications</i>
CNC Milling Machine	
	Speed: 0-18000 RPM Torque: 0.4Nm Accuracy: 0.01mm - 0.06mm
The “STEP57” stepper motor drives the lead screw.	Size: 57×64 mm Step angle: 1.8° Voltage: 24 VDC Torque: 3 Nm Operating temperature: -20°C to 50°C
Tool holder	01
Machining capability	Milling, engraving 2D and 3D shapes, letter engraving, drilling, machining on flat sheet stock, and round stock.

Table 2. The comparison results between the design model and the actual machined sample on the system for material feeding and automatic machining

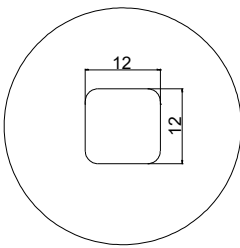
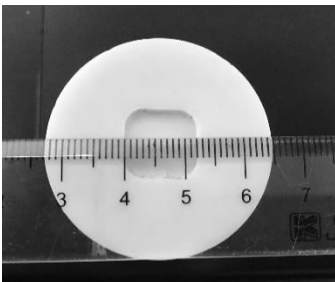
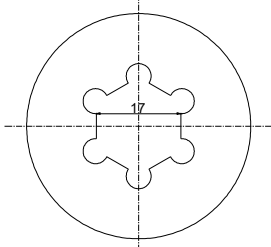
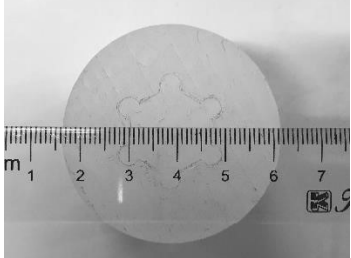
Sample	Design	Experiment
Number 1		
Number 2		

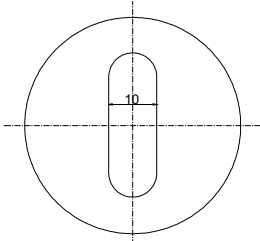
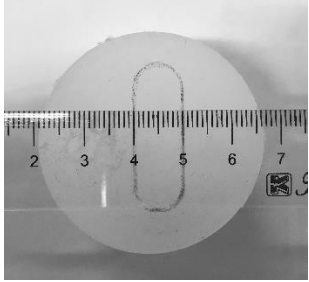
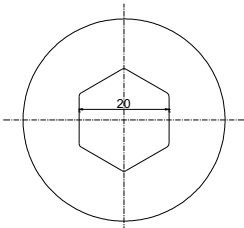
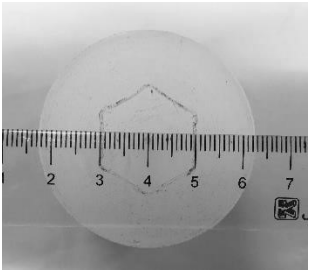
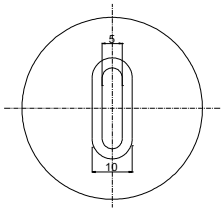
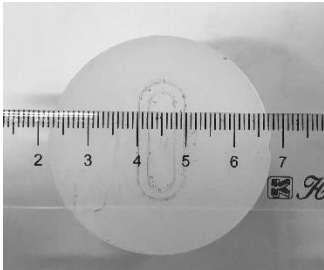
Number 3		
Number 4		
Number 5		

6. CONCLUSION

The authors have presented some research results on the design and manufacturing of a 3-axis mini CNC milling machine. The machine has been successfully fabricated and tested with the following outcomes:

- The machine is easy to operate, convenient in movement, and easy to maintain and service.
- It can engrave patterns, designs, logos, etc., on materials such as aluminum, colored metals, wood, plastic, etc.
- It can machine flat and cylindrical workpieces.

- It can be applied effectively in production and serves well for teaching programming and operating CNC machines.

REFERENCES

1. Tran Van Dich, (2004), *CNC Technology Textbook*, Science and Technics Publishing House.
2. Nguyen Ngoc Dao (2004), *CAD-CAM-CNC Textbook*, Ho Chi Minh City University of Education Publishing House.
3. Bui Quy Luc, (2006), *Industrial Digital Control System*, Science and Technics Publishing House.

4. <https://weldcom.vn/tong-quan-ve-may-phay-cnc-3-truc/>
5. <https://trangtri360.com/cat-cnc-go-tu-nhien/>
6. Website:
https://www.alibaba.com/product-detail/HY6040-stone-cnc-router-good-price_60819298482.html?spm=a2700.icbuShop.59114.3.4a4915dfBBJWLK
7. Website:
https://scotle.en.alibaba.com/product/1899985669-800620544/4_Axis_CNC_6040_China_Mini_DIY_Desktop_Hobby_CNC_Router_Kits_For_Sale_for_Woodworking_Advertising_Drilling_Milling.html
8. Dang Minh Phung, Le Hieu Giang, Nguyen Van Lam, Nguyen Truong Hai, Le Tan Cuong, (2015), *Research on Designing and Manufactorying 4 – Axis mini CNC Milling Machine using MACH3 software*, Proceeding of the 4th National Conference on Mechanical Science & Technology, Ho Chi Minh City University of Education Publishing House, Page 112- 120.